

Manual do Equipamento

MIG MAG · TIG · ARCO SUBMERSO · MULTIPROCESSO · RETIFICADORAS
CORTE PLASMA INVERSORAS · ELETRODO · GERADORES DE ENERGIA



a melhor locadora
temos tudo que sua
obra precisa

ACESSE NOSSO SITE

www.alugasolda.com.br

(11) 4617-9696



comercial@alugasolda.com.br





OM-246 466E

2012-06

Processes



Stick (SMAW) Welding



MIG (GMAW) Welding

RMD (Modified Short Circuit)

Pulsed MIG (GMAW-P)



Flux Cored (FCAW) Welding



TIG (GTAW) Welding



Multiprocess Welding

Description



Arc Welding Power Source

PipePro[®] 300

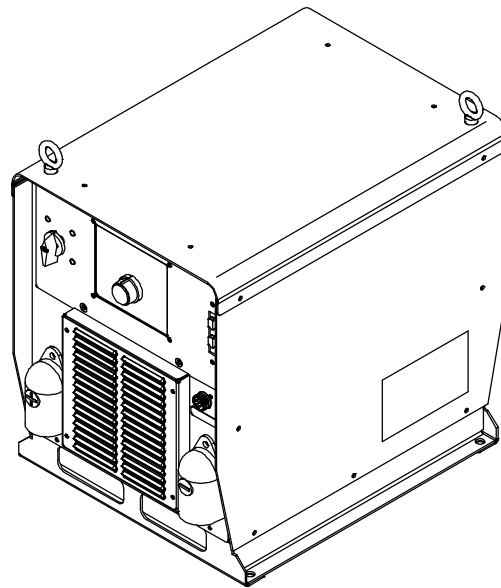

Visit our website at
www.MillerWelds.com

OWNER'S MANUAL

File: Pipe Welding Products



From Miller to You

Thank you and congratulations on choosing Miller. Now you can get the job done and get it done right. We know you don't have time to do it any other way.

That's why when Niels Miller first started building arc welders in 1929, he made sure his products offered long-lasting value and superior quality. Like you, his customers couldn't afford anything less. Miller products had to be more than the best they could be. They had to be the best you could buy.

Today, the people that build and sell Miller products continue the tradition. They're just as committed to providing equipment and service that meets the high standards of quality and value established in 1929.

This Owner's Manual is designed to help you get the most out of your Miller products. Please take time to read the Safety precautions. They will help you protect yourself against potential hazards on the worksite.

We've made installation and operation quick and easy. With Miller you can count on years of reliable service with proper maintenance. And if for some reason the unit needs repair, there's a Troubleshooting section that will help you figure out what the problem is. The parts list will then help you to decide the exact part you may need to fix the problem. Warranty and service information for your particular model are also provided.



Miller is the first welding equipment manufacturer in the U.S.A. to be registered to the ISO 9001 Quality System Standard.

Miller Electric manufactures a full line of welders and welding related equipment. For information on other quality Miller products, contact your local Miller distributor to receive the latest full line catalog or individual specification sheets. **To locate your nearest distributor or service agency call 1-800-4-A-Miller, or visit us at www.MillerWelds.com on the web.**



Working as hard as you do – every power source from Miller is backed by the most hassle-free warranty in the business.



TABLE OF CONTENTS

SECTION 1 – SAFETY PRECAUTIONS - READ BEFORE USING	1
1-1. Symbol Usage	1
1-2. Arc Welding Hazards	1
1-3. Additional Symbols For Installation, Operation, And Maintenance	3
1-4. California Proposition 65 Warnings	4
1-5. Principal Safety Standards	4
1-6. EMF Information	4
SECTION 2 – CONSIGNES DE SÉCURITÉ – LIRE AVANT UTILISATION	5
2-1. Symboles utilisés	5
2-2. Dangers relatifs au soudage à l'arc	5
2-3. Dangers supplémentaires en relation avec l'installation, le fonctionnement et la maintenance	7
2-4. Proposition californienne 65 Avertissements	8
2-5. Principales normes de sécurité	9
2-6. Informations relatives aux CEM	9
SECTION 3 – SPECIFICATIONS	11
3-1. Specifications	11
3-2. Dimensions And Weight	11
3-3. Duty Cycle And Overheating	12
SECTION 4 – INSTALLATION	13
4-1. Serial Number And Rating Label Location	13
4-2. Selecting A Location	13
4-3. Proper Ring Terminal Connection To Volt Sense Lead	14
4-4. Connecting Volt Sense Lead And Work Cable To Clamp	14
4-5. Connecting To Weld Terminals	15
4-6. Selecting Weld Cable Sizes*	16
4-7. Arranging Welding Cables To Reduce Welding Circuit Inductance (Suitcase Feeder)	17
4-8. Voltage Sensing Lead And Work Cable Connections For Multiple Welding Arcs (Suitcase Feeder)	18
4-9. Rear Panel Receptacles And Supplementary Protectors	20
4-10. Peripheral Receptacle Functions	20
4-11. Motor Control Receptacle Functions	21
4-12. Remote 14 Receptacle Information	21
4-13. Electrical Service Guide	22
4-14. Connecting 3-Phase Input Power	23
SECTION 5 – OPERATION	25
5-1. Operational Terms	25
5-2. Front Panel Controls (See Section 5-3)	26
5-3. Front Panel Controls - Continued (See Section 5-2)	27
5-4. Typical Connection Diagram For MIG (GMAW) Equipment Using A Suitcase Feeder	28
5-5. PipePro 300 Set Up For MIG (GMAW) Equipment	29
5-6. Typical Connection Diagram For TIG (GTAW) Equipment	30
5-7. PipePro 300 Set Up For Lift TIG (GTAW) Equipment	31
5-8. Typical Connection Diagram For Stick (SMAW) Equipment	32
5-9. PipePro 300 Set Up For Stick (SMAW) Equipment	33
5-10. Isolating Two Processes Using Polarity Reversing/Isolation Control (042 871) Without HF Unit	34
5-11. Isolating Three Processes Using Polarity Reversing/Isolation Control (042 871) Without HF Unit	34
5-12. Front Panel Switches	37
5-13. Basic Parameters For PipePro 300	38
5-14. Welding Stainless Steel With And Without Backing Gas Using PipePro 300	40
5-15. Checking Program Revision	40
5-16. Reset Mode	41

TABLE OF CONTENTS

SECTION 6 – MAINTENANCE	42
6-1. Routine Maintenance	42
6-2. Blowing Out Inside Of Unit	42
SECTION 7 – SAFETY PRECAUTIONS FOR SERVICING	43
7-1. Symbol Usage	43
7-2. Servicing Hazards	43
7-3. California Proposition 65 Warnings	44
7-4. EMF Information	44
SECTION 8 – TROUBLESHOOTING	45
8-1. Set Value Mode	45
8-2. Troubleshooting Welding Power Source/Wire Feeder Issues	46
8-3. Diagnostics	47
8-4. Removing Cover and Measuring Input Capacitor Voltage	48
8-5. Process Control Module PC4 Diagnostic LEDs	49
8-6. Diagnostic LEDs On Process Control Module PC4	49
8-7. User Interface Module PC7 Diagnostic LEDs	50
8-8. Diagnostic LEDs On User Interface Module PC7	50
8-9. Automation Interface Module PC9 Diagnostic LEDs	51
8-10. Diagnostic LEDs On Automation Interface Module PC9	52
8-11. Network And Module Status LEDs	54
8-12. Troubleshooting	54
SECTION 9 – ELECTRICAL DIAGRAMS	56
SECTION 10 – PARTS LIST	58
WARRANTY	

SECTION 1 – SAFETY PRECAUTIONS - READ BEFORE USING

som 2011-10

 Protect yourself and others from injury — read, follow, and save these important safety precautions and operating instructions.

1-1. Symbol Usage



DANGER! – Indicates a hazardous situation which, if not avoided, will result in death or serious injury. The possible hazards are shown in the adjoining symbols or explained in the text.



Indicates a hazardous situation which, if not avoided, could result in death or serious injury. The possible hazards are shown in the adjoining symbols or explained in the text.

NOTICE – Indicates statements not related to personal injury.

 Indicates special instructions.



This group of symbols means Warning! Watch Out! ELECTRIC SHOCK, MOVING PARTS, and HOT PARTS hazards. Consult symbols and related instructions below for necessary actions to avoid the hazards.

1-2. Arc Welding Hazards



The symbols shown below are used throughout this manual to call attention to and identify possible hazards. When you see the symbol, watch out, and follow the related instructions to avoid the hazard. The safety information given below is only a summary of the more complete safety information found in the Safety Standards listed in Section 1-5. Read and follow all Safety Standards.



Only qualified persons should install, operate, maintain, and repair this unit.



During operation, keep everybody, especially children, away.



ELECTRIC SHOCK can kill.

Touching live electrical parts can cause fatal shocks or severe burns. The electrode and work circuit is electrically live whenever the output is on. The input power circuit and machine internal circuits are also live when power is on. In semiautomatic or automatic wire welding, the wire, wire reel, drive roll housing, and all metal parts touching the welding wire are electrically live. Incorrectly installed or improperly grounded equipment is a hazard.

- Do not touch live electrical parts.
- Wear dry, hole-free insulating gloves and body protection.
- Insulate yourself from work and ground using dry insulating mats or covers big enough to prevent any physical contact with the work or ground.
- Do not use AC output in damp areas, if movement is confined, or if there is a danger of falling.
- Use AC output ONLY if required for the welding process.
- If AC output is required, use remote output control if present on unit.
- Additional safety precautions are required when any of the following electrically hazardous conditions are present: in damp locations or while wearing wet clothing; on metal structures such as floors, gratings, or scaffolds; when in cramped positions such as sitting, kneeling, or lying; or when there is a high risk of unavoidable or accidental contact with the workpiece or ground. For these conditions, use the following equipment in order presented: 1) a semiautomatic DC constant voltage (wire) welder, 2) a DC manual (stick) welder, or 3) an AC welder with reduced open-circuit voltage. In most situations, use of a DC, constant voltage wire welder is recommended. And, do not work alone!
- Disconnect input power or stop engine before installing or servicing this equipment. Lockout/tagout input power according to OSHA 29 CFR 1910.147 (see Safety Standards).
- Properly install, ground, and operate this equipment according to its Owner's Manual and national, state, and local codes.

- Always verify the supply ground – check and be sure that input power cord ground wire is properly connected to ground terminal in disconnect box or that cord plug is connected to a properly grounded receptacle outlet.
- When making input connections, attach proper grounding conductor first – double-check connections.
- Keep cords dry, free of oil and grease, and protected from hot metal and sparks.
- Frequently inspect input power cord for damage or bare wiring – replace cord immediately if damaged – bare wiring can kill.
- Turn off all equipment when not in use.
- Do not use worn, damaged, undersized, or poorly spliced cables.
- Do not drape cables over your body.
- If earth grounding of the workpiece is required, ground it directly with a separate cable.
- Do not touch electrode if you are in contact with the work, ground, or another electrode from a different machine.
- Do not touch electrode holders connected to two welding machines at the same time since double open-circuit voltage will be present.
- Use only well-maintained equipment. Repair or replace damaged parts at once. Maintain unit according to manual.
- Wear a safety harness if working above floor level.
- Keep all panels and covers securely in place.
- Clamp work cable with good metal-to-metal contact to workpiece or worktable as near the weld as practical.
- Insulate work clamp when not connected to workpiece to prevent contact with any metal object.
- Do not connect more than one electrode or work cable to any single weld output terminal. Disconnect cable for process not in use.

SIGNIFICANT DC VOLTAGE exists in inverter welding power sources AFTER removal of input power.

- Turn Off inverter, disconnect input power, and discharge input capacitors according to instructions in Maintenance Section before touching any parts.



HOT PARTS can burn.

- Do not touch hot parts bare handed.
- Allow cooling period before working on equipment.
- To handle hot parts, use proper tools and/or wear heavy, insulated welding gloves and clothing to prevent burns.



FUMES AND GASES can be hazardous.

Welding produces fumes and gases. Breathing these fumes and gases can be hazardous to your health.

- Keep your head out of the fumes. Do not breathe the fumes.
- If inside, ventilate the area and/or use local forced ventilation at the arc to remove welding fumes and gases.
- If ventilation is poor, wear an approved air-supplied respirator.
- Read and understand the Material Safety Data Sheets (MSDSs) and the manufacturer's instructions for metals, consumables, coatings, cleaners, and degreasers.
- Work in a confined space only if it is well ventilated, or while wearing an air-supplied respirator. Always have a trained watch-person nearby. Welding fumes and gases can displace air and lower the oxygen level causing injury or death. Be sure the breathing air is safe.
- Do not weld in locations near degreasing, cleaning, or spraying operations. The heat and rays of the arc can react with vapors to form highly toxic and irritating gases.
- Do not weld on coated metals, such as galvanized, lead, or cadmium plated steel, unless the coating is removed from the weld area, the area is well ventilated, and while wearing an air-supplied respirator. The coatings and any metals containing these elements can give off toxic fumes if welded.



ARC RAYS can burn eyes and skin.

Arc rays from the welding process produce intense visible and invisible (ultraviolet and infrared) rays that can burn eyes and skin. Sparks fly off from the weld.

- Wear an approved welding helmet fitted with a proper shade of filter lenses to protect your face and eyes from arc rays and sparks when welding or watching (see ANSI Z49.1 and Z87.1 listed in Safety Standards).
- Wear approved safety glasses with side shields under your helmet.
- Use protective screens or barriers to protect others from flash, glare and sparks; warn others not to watch the arc.
- Wear protective clothing made from durable, flame-resistant material (leather, heavy cotton, or wool) and foot protection.



WELDING can cause fire or explosion.

Welding on closed containers, such as tanks, drums, or pipes, can cause them to blow up. Sparks can fly off from the welding arc. The flying sparks, hot workpiece, and hot equipment can cause fires and burns. Accidental contact of electrode to metal objects can cause sparks, explosion, overheating, or fire. Check and be sure the area is safe before doing any welding.

- Remove all flammables within 35 ft (10.7 m) of the welding arc. If this is not possible, tightly cover them with approved covers.
- Do not weld where flying sparks can strike flammable material.
- Protect yourself and others from flying sparks and hot metal.
- Be alert that welding sparks and hot materials from welding can easily go through small cracks and openings to adjacent areas.
- Watch for fire, and keep a fire extinguisher nearby.
- Be aware that welding on a ceiling, floor, bulkhead, or partition can cause fire on the hidden side.
- Do not weld on containers that have held combustibles, or on closed containers such as tanks, drums, or pipes unless they are properly prepared according to AWS F4.1 and AWS A6.0 (see Safety Standards).
- Do not weld where the atmosphere may contain flammable dust, gas, or liquid vapors (such as gasoline).
- Connect work cable to the work as close to the welding area as practical to prevent welding current from traveling long, possibly unknown paths and causing electric shock, sparks, and fire hazards.
- Do not use welder to thaw frozen pipes.

- Remove stick electrode from holder or cut off welding wire at contact tip when not in use.
- Wear oil-free protective garments such as leather gloves, heavy shirt, cuffless trousers, high shoes, and a cap.
- Remove any combustibles, such as a butane lighter or matches, from your person before doing any welding.
- After completion of work, inspect area to ensure it is free of sparks, glowing embers, and flames.
- Use only correct fuses or circuit breakers. Do not oversize or bypass them.
- Follow requirements in OSHA 1910.252 (a) (2) (iv) and NFPA 51B for hot work and have a fire watcher and extinguisher nearby.

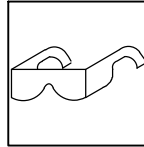

FLYING METAL or DIRT can injure eyes.

- Welding, chipping, wire brushing, and grinding cause sparks and flying metal. As welds cool, they can throw off slag.
- Wear approved safety glasses with side shields even under your welding helmet.



BUILDUP OF GAS can injure or kill.

- Shut off compressed gas supply when not in use.
- Always ventilate confined spaces or use approved air-supplied respirator.

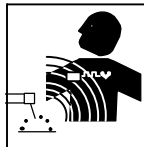

ELECTRIC AND MAGNETIC FIELDS (EMF) can affect Implanted Medical Devices.

- Wearers of Pacemakers and other Implanted Medical Devices should keep away.
- Implanted Medical Device wearers should consult their doctor and the device manufacturer before going near arc welding, spot welding, gouging, plasma arc cutting, or induction heating operations.

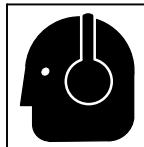

NOISE can damage hearing.

Noise from some processes or equipment can damage hearing.

- Wear approved ear protection if noise level is high.

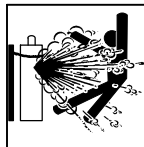

CYLINDERS can explode if damaged.

Compressed gas cylinders contain gas under high pressure. If damaged, a cylinder can explode. Since gas cylinders are normally part of the welding process, be sure to treat them carefully.

- Protect compressed gas cylinders from excessive heat, mechanical shocks, physical damage, slag, open flames, sparks, and arcs.
- Install cylinders in an upright position by securing to a stationary support or cylinder rack to prevent falling or tipping.
- Keep cylinders away from any welding or other electrical circuits.
- Never drape a welding torch over a gas cylinder.
- Never allow a welding electrode to touch any cylinder.
- Never weld on a pressurized cylinder – explosion will result.
- Use only correct compressed gas cylinders, regulators, hoses, and fittings designed for the specific application; maintain them and associated parts in good condition.
- Turn face away from valve outlet when opening cylinder valve.
- Keep protective cap in place over valve except when cylinder is in use or connected for use.
- Use the right equipment, correct procedures, and sufficient number of persons to lift and move cylinders.
- Read and follow instructions on compressed gas cylinders, associated equipment, and Compressed Gas Association (CGA) publication P-1 listed in Safety Standards.

1-3. Additional Symbols For Installation, Operation, And Maintenance



FIRE OR EXPLOSION hazard.

- Do not install or place unit on, over, or near combustible surfaces.
- Do not install unit near flammables.
- Do not overload building wiring – be sure power supply system is properly sized, rated, and protected to handle this unit.



FALLING EQUIPMENT can injure.

- Use lifting eye to lift unit only, NOT running gear, gas cylinders, or any other accessories.
- Use equipment of adequate capacity to lift and support unit.
- If using lift forks to move unit, be sure forks are long enough to extend beyond opposite side of unit.
- Keep equipment (cables and cords) away from moving vehicles when working from an aerial location.
- Follow the guidelines in the Applications Manual for the Revised NIOSH Lifting Equation (Publication No. 94-110) when manually lifting heavy parts or equipment.

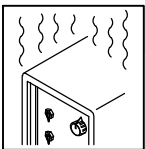

OVERUSE can cause OVERHEATING

- Allow cooling period; follow rated duty cycle.
- Reduce current or reduce duty cycle before starting to weld again.
- Do not block or filter airflow to unit.

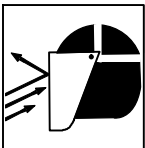

FLYING SPARKS can injure.

- Wear a face shield to protect eyes and face.
- Shape tungsten electrode only on grinder with proper guards in a safe location wearing proper face, hand, and body protection.
- Sparks can cause fires — keep flammables away.

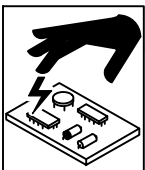

STATIC (ESD) can damage PC boards.

- Put on grounded wrist strap BEFORE handling boards or parts.
- Use proper static-proof bags and boxes to store, move, or ship PC boards.



MOVING PARTS can injure.

- Keep away from moving parts.
- Keep away from pinch points such as drive rolls.



WELDING WIRE can injure.

- Do not press gun trigger until instructed to do so.
- Do not point gun toward any part of the body, other people, or any metal when threading welding wire.

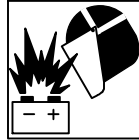

BATTERY EXPLOSION can injure.

- Do not use welder to charge batteries or jump start vehicles unless it has a battery charging feature designed for this purpose.



MOVING PARTS can injure.

- Keep away from moving parts such as fans.
- Keep all doors, panels, covers, and guards closed and securely in place.
- Have only qualified persons remove doors, panels, covers, or guards for maintenance and troubleshooting as necessary.
- Reinstall doors, panels, covers, or guards when maintenance is finished and before reconnecting input power.

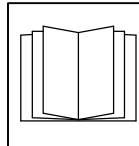

READ INSTRUCTIONS.

- Read and follow all labels and the Owner's Manual carefully before installing, operating, or servicing unit. Read the safety information at the beginning of the manual and in each section.
- Use only genuine replacement parts from the manufacturer.
- Perform maintenance and service according to the Owner's Manuals, industry standards, and national, state, and local codes.

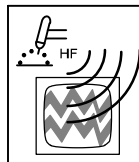

H.F. RADIATION can cause interference.

- High-frequency (H.F.) can interfere with radio navigation, safety services, computers, and communications equipment.
- Have only qualified persons familiar with electronic equipment perform this installation.
- The user is responsible for having a qualified electrician promptly correct any interference problem resulting from the installation.
- If notified by the FCC about interference, stop using the equipment at once.
- Have the installation regularly checked and maintained.
- Keep high-frequency source doors and panels tightly shut, keep spark gaps at correct setting, and use grounding and shielding to minimize the possibility of interference.

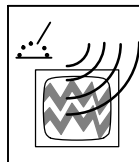

ARC WELDING can cause interference.

- Electromagnetic energy can interfere with sensitive electronic equipment such as computers and computer-driven equipment such as robots.
- Be sure all equipment in the welding area is electromagnetically compatible.
- To reduce possible interference, keep weld cables as short as possible, close together, and down low, such as on the floor.
- Locate welding operation 100 meters from any sensitive electronic equipment.
- Be sure this welding machine is installed and grounded according to this manual.
- If interference still occurs, the user must take extra measures such as moving the welding machine, using shielded cables, using line filters, or shielding the work area.

1-4. California Proposition 65 Warnings

 **Welding or cutting equipment produces fumes or gases which contain chemicals known to the State of California to cause birth defects and, in some cases, cancer. (California Health & Safety Code Section 25249.5 et seq.)**

 **This product contains chemicals, including lead, known to the state of California to cause cancer, birth defects, or other reproductive harm. Wash hands after use.**

1-5. Principal Safety Standards

Safety in Welding, Cutting, and Allied Processes, ANSI Standard Z49.1, is available as a free download from the American Welding Society at <http://www.aws.org> or purchased from Global Engineering Documents (phone: 1-877-413-5184, website: www.global.ihs.com).

Safe Practices for the Preparation of Containers and Piping for Welding and Cutting, American Welding Society Standard AWS F4.1, from Global Engineering Documents (phone: 1-877-413-5184, website: www.global.ihs.com).

Safe Practices for Welding and Cutting Containers that have Held Combustibles, American Welding Society Standard AWS A6.0, from Global Engineering Documents (phone: 1-877-413-5184, website: www.global.ihs.com).

National Electrical Code, NFPA Standard 70, from National Fire Protection Association, Quincy, MA 02269 (phone: 1-800-344-3555, website: www.nfpa.org and www.sparky.org).

Safe Handling of Compressed Gases in Cylinders, CGA Pamphlet P-1, from Compressed Gas Association, 14501 George Carter Way, Suite 103, Chantilly, VA 20151 (phone: 703-788-2700, website: www.cganet.com).

Safety in Welding, Cutting, and Allied Processes, CSA Standard W117.2, from Canadian Standards Association, Standards Sales, 5060

Spectrum Way, Suite 100, Ontario, Canada L4W 5N5 (phone: 800-463-6727, website: www.csa-international.org).

Safe Practice For Occupational And Educational Eye And Face Protection, ANSI Standard Z87.1, from American National Standards Institute, 25 West 43rd Street, New York, NY 10036 (phone: 212-642-4900, website: www.ansi.org).

Standard for Fire Prevention During Welding, Cutting, and Other Hot Work, NFPA Standard 51B, from National Fire Protection Association, Quincy, MA 02269 (phone: 1-800-344-3555, website: www.nfpa.org).

OSHA, Occupational Safety and Health Standards for General Industry, Title 29, Code of Federal Regulations (CFR), Part 1910, Subpart Q, and Part 1926, Subpart J, from U.S. Government Printing Office, Superintendent of Documents, P.O. Box 371954, Pittsburgh, PA 15250-7954 (phone: 1-866-512-1800) (there are 10 OSHA Regional Offices—phone for Region 5, Chicago, is 312-353-2220, website: www.osha.gov).

Applications Manual for the Revised NIOSH Lifting Equation, The National Institute for Occupational Safety and Health (NIOSH), 1600 Clifton Rd, Atlanta, GA 30333 (phone: 1-800-232-4636, website: www.cdc.gov/NIOSH).

1-6. EMF Information

Electric current flowing through any conductor causes localized electric and magnetic fields (EMF). Welding current creates an EMF field around the welding circuit and welding equipment. EMF fields may interfere with some medical implants, e.g. pacemakers. Protective measures for persons wearing medical implants have to be taken. For example, restrict access for passers-by or conduct individual risk assessment for welders. All welders should use the following procedures in order to minimize exposure to EMF fields from the welding circuit:

1. Keep cables close together by twisting or taping them, or using a cable cover.
2. Do not place your body between welding cables. Arrange cables to one side and away from the operator.
3. Do not coil or drape cables around your body.

4. Keep head and trunk as far away from the equipment in the welding circuit as possible.
5. Connect work clamp to workpiece as close to the weld as possible.
6. Do not work next to, sit or lean on the welding power source.
7. Do not weld whilst carrying the welding power source or wire feeder.

About Implanted Medical Devices:

Implanted Medical Device wearers should consult their doctor and the device manufacturer before performing or going near arc welding, spot welding, gouging, plasma arc cutting, or induction heating operations. If cleared by your doctor, then following the above procedures is recommended.

SECTION 2 – CONSIGNES DE SÉCURITÉ – LIRE AVANT UTILISATION

fre_som_2011-10

⚠ Pour écarter les risques de blessure pour vous-même et pour autrui — lire, appliquer et ranger en lieu sûr ces consignes relatives aux précautions de sécurité et au mode opératoire.

2-1. Symboles utilisés



DANGER! – Indique une situation dangereuse qui si on l'évite pas peut donner la mort ou des blessures graves. Les dangers possibles sont montrés par les symboles joints ou sont expliqués dans le texte.



Indique une situation dangereuse qui si on l'évite pas peut donner la mort ou des blessures graves. Les dangers possibles sont montrés par les symboles joints ou sont expliqués dans le texte.

NOTE – Indique des déclarations pas en relation avec des blessures personnelles.

Indique des instructions spécifiques.



Ce groupe de symboles veut dire Avertissement! Attention! DANGER DE CHOC ELECTRIQUE, PIECES EN MOUVEMENT, et PIECES CHAUDES. Consulter les symboles et les instructions ci-dessous y afférant pour les actions nécessaires afin d'éviter le danger.

2-2. Dangers relatifs au soudage à l'arc



Les symboles représentés ci-dessous sont utilisés dans ce manuel pour attirer l'attention et identifier les dangers possibles. En présence de l'un de ces symboles, prendre garde et suivre les instructions afférentes pour éviter tout risque. Les instructions en matière de sécurité indiquées ci-dessous ne constituent qu'un sommaire des instructions de sécurité plus complètes fournies dans les normes de sécurité énumérées dans la Section 2-5. Lire et observer toutes les normes de sécurité.



Seul un personnel qualifié est autorisé à installer, faire fonctionner, entretenir et réparer cet appareil.



Pendant le fonctionnement, maintenir à distance toutes les personnes, notamment les enfants de l'appareil.



UNE DÉCHARGE ÉLECTRIQUE peut entraîner la mort.

Le contact d'organes électriques sous tension peut provoquer des accidents mortels ou des brûlures graves. Le circuit de l'électrode et de la pièce est sous tension lorsque le courant est délivré à la sortie. Le circuit d'alimentation et les circuits internes de la machine sont également sous tension lorsque l'alimentation est sur Marche. Dans le mode de soudage avec du fil, le fil, le dérouleur, le bloc de commande du rouleau et toutes les parties métalliques en contact avec le fil sont sous tension électrique. Un équipement installé ou mis à la terre de manière incorrecte ou impropre constitue un danger.

- Ne pas toucher aux pièces électriques sous tension.
- Porter des gants isolants et des vêtements de protection secs et sans trous.
- S'isoler de la pièce à couper et du sol en utilisant des housses ou des tapis assez grands afin d'éviter tout contact physique avec la pièce à couper ou le sol.
- Ne pas se servir de source électrique à courant électrique dans les zones humides, dans les endroits confinés ou là où on risque de tomber.
- Se servir d'une source électrique à courant électrique UNIQUEMENT si le procédé de soudage le demande.
- Si l'utilisation d'une source électrique à courant électrique s'avère nécessaire, se servir de la fonction de télécommande si l'appareil en est équipé.
- D'autres consignes de sécurité sont nécessaires dans les conditions suivantes : risques électriques dans un environnement humide ou si l'on porte des vêtements mouillés ; sur des structures métalliques telles que sols, grilles ou échafaudages ; en position coincée comme assise, à genoux ou couchée ; ou s'il y a un risque élevé de contact inévitable ou accidentel avec la pièce à souder ou le sol. Dans ces conditions, utiliser les équipements suivants,

dans l'ordre indiqué : 1) un poste à souder DC à tension constante (à fil), 2) un poste à souder DC manuel (électrode) ou 3) un poste à souder AC à tension à vide réduite. Dans la plupart des situations, l'utilisation d'un poste à souder DC à fil à tension constante est recommandée. En outre, ne pas travailler seul !

- Couper l'alimentation ou arrêter le moteur avant de procéder à l'installation, à la réparation ou à l'entretien de l'appareil. Déverrouiller l'alimentation selon la norme OSHA 29 CFR 1910.147 (voir normes de sécurité).
- Installez, mettez à la terre et utilisez correctement cet équipement conformément à son Manuel d'Utilisation et aux réglementations nationales, gouvernementales et locales.
- Toujours vérifier la terre du cordon d'alimentation. Vérifier et s'assurer que le fil de terre du cordon d'alimentation est bien raccordé à la borne de terre du sectionneur ou que la fiche du cordon est raccordée à une prise correctement mise à la terre.
- En effectuant les raccordements d'entrée, fixer d'abord le conducteur de mise à la terre approprié et contre-vérifier les connexions.
- Les câbles doivent être exempts d'humidité, d'huile et de graisse; protégez-les contre les étincelles et les pièces métalliques chaudes.
- Vérifier fréquemment le cordon d'alimentation afin de s'assurer qu'il n'est pas altéré ou à nu, le remplacer immédiatement s'il l'est. Un fil à nu peut entraîner la mort.
- L'équipement doit être hors tension lorsqu'il n'est pas utilisé.
- Ne pas utiliser des câbles usés, endommagés, de grosseur insuffisante ou mal épissés.
- Ne pas enrouler les câbles autour du corps.
- Si la pièce soudée doit être mise à la terre, le faire directement avec un câble distinct.
- Ne pas toucher l'électrode quand on est en contact avec la pièce, la terre ou une électrode provenant d'une autre machine.
- Ne pas toucher des porte électrodes connectés à deux machines en même temps à cause de la présence d'une tension à vide doublée.
- N'utiliser qu'un matériel en bon état. Réparer ou remplacer sur-le-champ les pièces endommagées. Entretenir l'appareil conformément à ce manuel.
- Porter un harnais de sécurité si l'on doit travailler au-dessus du sol.
- S'assurer que tous les panneaux et couvercles sont correctement en place.
- Fixer le câble de retour de façon à obtenir un bon contact métal-métal avec la pièce à souder ou la table de travail, le plus près possible de la soudure.
- Isoler la pince de masse quand pas mis à la pièce pour éviter le contact avec tout objet métallique.
- Ne pas raccorder plus d'une électrode ou plus d'un câble de masse à une même borne de sortie de soudage. Débrancher le câble pour le procédé non utilisé.

Il reste une TENSION DC NON NÉGLIGEABLE dans les sources de soudage onduleur UNE FOIS l'alimentation coupée.

- Arrêter les convertisseurs, débrancher le courant électrique et décharger les condensateurs d'alimentation selon les instructions indiquées dans la partie Entretien avant de toucher les pièces.



LES PIÈCES CHAUDES peuvent provoquer des brûlures.

- Ne pas toucher à mains nues les parties chaudes.
- Prévoir une période de refroidissement avant de travailler à l'équipement.
- Ne pas toucher aux pièces chaudes, utiliser les outils recommandés et porter des gants de soudage et des vêtements épais pour éviter les brûlures.



LES FUMÉES ET LES GAZ peuvent être dangereux.

Le soudage génère des fumées et des gaz. Leur inhalation peut être dangereux pour votre santé.

- Eloigner votre tête des fumées. Ne pas respirer les fumées.
- À l'intérieur, ventiler la zone et/ou utiliser une ventilation forcée au niveau de l'arc pour l'évacuation des fumées et des gaz de soudage.
- Si la ventilation est médiocre, porter un respirateur anti-vapeurs approuvé.
- Lire et comprendre les spécifications de sécurité des matériaux (MSDS) et les instructions du fabricant concernant les métaux, les consommables, les revêtements, les nettoyants et les dégraissants.
- Travailler dans un espace fermé seulement s'il est bien ventilé ou en portant un respirateur à alimentation d'air. Demander toujours à un surveillant dûment formé de se tenir à proximité. Des fumées et des gaz de soudage peuvent déplacer l'air et abaisser le niveau d'oxygène provoquant des blessures ou des accidents mortels. S'assurer que l'air de respiration ne présente aucun danger.
- Ne pas souder dans des endroits situés à proximité d'opérations de dégraissage, de nettoyage ou de pulvérisation. La chaleur et les rayons de l'arc peuvent réagir en présence de vapeurs et former des gaz hautement toxiques et irritants.
- Ne pas souder des métaux munis d'un revêtement, tels que l'acier galvanisé, plaqué en plomb ou au cadmium à moins que le revêtement n'ait été enlevé dans la zone de soudure, que l'endroit soit bien ventilé, et en portant un respirateur à alimentation d'air. Les revêtements et tous les métaux renfermant ces éléments peuvent dégager des fumées toxiques en cas de soudage.



LES RAYONS DE L'ARC peuvent provoquer des brûlures dans les yeux et sur la peau.

Le rayonnement de l'arc du procédé de soudage génère des rayons visibles et invisibles intenses (ultraviolets et infrarouges) susceptibles de provoquer des brûlures dans les yeux et sur la peau. Des étincelles sont projetées pendant le soudage.

- Porter un casque de soudage approuvé muni de verres filtrants appropriés pour protéger visage et yeux pour protéger votre visage et vos yeux pendant le soudage ou pour regarder (voir ANSI Z49.1 et Z87.1 énuméré dans les normes de sécurité).
- Porter des lunettes de sécurité avec écrans latéraux même sous votre casque.
- Avoir recours à des écrans protecteurs ou à des rideaux pour protéger les autres contre les rayonnements les éblouissements et les étincelles ; prévenir toute personne sur les lieux de ne pas regarder l'arc.
- Porter des vêtements confectionnés avec des matières résistantes et ignifuges (cuir, coton lourd ou laine) et des bottes de protection.



LE SOUDAGE peut provoquer un incendie ou une explosion.

Le soudage effectué sur des conteneurs fermés tels que des réservoirs, tambours ou des conduites peut provoquer leur éclatement. Des étincelles peuvent être projetées de l'arc de soudure. La projection d'étincelles, des pièces chaudes et des équipements chauds peut provoquer des incendies et des brûlures. Le contact accidentel de l'électrode avec des objets métalliques peut provoquer des étincelles, une explosion, un surchauffement ou un incendie. Avant de commencer le soudage, vérifier et s'assurer que l'endroit ne présente pas de danger.

- Déplacer toutes les substances inflammables à une distance de 10,7 m de l'arc de soudage. En cas d'impossibilité les recouvrir soigneusement avec des protections homologuées.
- Ne pas souder dans un endroit où des étincelles peuvent tomber sur des substances inflammables.
- Se protéger et d'autres personnes de la projection d'étincelles et de métal chaud.
- Des étincelles et des matériaux chauds du soudage peuvent facilement passer dans d'autres zones en traversant de petites fissures et des ouvertures.
- Surveiller tout déclenchement d'incendie et tenir un extincteur à proximité.
- Le soudage effectué sur un plafond, plancher, paroi ou séparation peut déclencher un incendie de l'autre côté.
- Ne pas effectuer le soudage sur des conteneurs fermés tels que des réservoirs, tambours, ou conduites, à moins qu'ils n'aient été préparés correctement conformément à AWS F4.1 et AWS A6.0 (voir les Normes de Sécurité).
- Ne soudez pas si l'air ambiant est chargé de particules, gaz, ou vapeurs inflammables (vapeur d'essence, par exemple).
- Brancher le câble de masse sur la pièce la plus près possible de la zone de soudage pour éviter le transport du courant sur une longue distance par des chemins inconnus éventuels en provoquant des risques d'électrocution, d'étincelles et d'incendie.
- Ne pas utiliser le poste de soudage pour dégeler des conduites gelées.
- En cas de non utilisation, enlever la baguette d'électrode du porte-électrode ou couper le fil à la pointe de contact.
- Porter des vêtements de protection dépourvus d'huile tels que des gants en cuir, une chemise en matériau lourd, des pantalons sans revers, des chaussures hautes et un couvre chef.
- Avant de souder, retirer toute substance combustible de vos poches telles qu'un allumeur au butane ou des allumettes.
- Une fois le travail achevé, assurez-vous qu'il ne reste aucune trace d'étincelles incandescentes ni de flammes.
- Utiliser exclusivement des fusibles ou coupe-circuits appropriés. Ne pas augmenter leur puissance; ne pas les ponter.
- Une fois le travail achevé, assurez-vous qu'il ne reste aucune trace d'étincelles incandescentes ni de flammes.
- Utiliser exclusivement des fusibles ou coupe-circuits appropriés. Ne pas augmenter leur puissance; ne pas les ponter.
- Suivre les recommandations dans OSHA 1910.252(a)(2)(iv) et NFPA 51B pour les travaux à chaud et avoir de la surveillance et un extincteur à proximité.

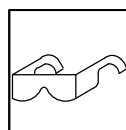

DES PIÈCES DE METAL ou DES SALETES peuvent provoquer des blessures dans les yeux.

- Le soudage, l'écaillage, le passage de la pièce à la brosse en fil de fer, et le meulage génèrent des étincelles et des particules métalliques volantes. Pendant la période de refroidissement des soudures, elles risquent de projeter du laitier.
- Porter des lunettes de sécurité avec écrans latéraux ou un écran facial.



LES ACCUMULATIONS DE GAZ risquent de provoquer des blessures ou même la mort.

- Fermer l'alimentation du gaz comprimé en cas de non utilisation.
- Veiller toujours à bien aérer les espaces confinés ou se servir d'un respirateur d'adduction d'air homologué.



Les CHAMPS ÉLECTROMAGNÉTIQUES (CEM) peuvent affecter les implants médicaux.

- Les porteurs de stimulateurs cardiaques et autres implants médicaux doivent rester à distance.
- Les porteurs d'implants médicaux doivent consulter leur médecin et le fabricant du dispositif avant de s'approcher de la zone où se déroule du soudage à l'arc, du soudage par points, du gougeage, de la découpe plasma ou une opération de chauffage par induction.



LE BRUIT peut endommager l'ouïe.

Le bruit des processus et des équipements peut affecter l'ouïe.

- Porter des protections approuvées pour les oreilles si le niveau sonore est trop élevé.

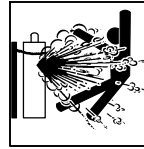

LES BOUTEILLES peuvent exploser si elles sont endommagées.

Les bouteilles de gaz comprimé contiennent du gaz sous haute pression. Si une bouteille est endommagée, elle peut exploser. Du fait que les bouteilles de gaz font normalement partie du procédé de soudage, les manipuler avec précaution.

- Protéger les bouteilles de gaz comprimé d'une chaleur excessive, des chocs mécaniques, des dommages physiques, du laitier, des flammes ouvertes, des étincelles et des arcs.
- Placer les bouteilles debout en les fixant dans un support stationnaire ou dans un porte-bouteilles pour les empêcher de tomber ou de se renverser.
- Tenir les bouteilles éloignées des circuits de soudage ou autres circuits électriques.
- Ne jamais placer une torche de soudage sur une bouteille à gaz.
- Une électrode de soudage ne doit jamais entrer en contact avec une bouteille.
- Ne jamais souder une bouteille pressurisée – risque d'explosion.
- Utiliser seulement des bouteilles de gaz comprimé, régulateurs, tuyaux et raccords convenables pour cette application spécifique; les maintenir ainsi que les éléments associés en bon état.
- Détourner votre visage du détendeur-régulateur lorsque vous ouvrez la soupape de la bouteille.
- Le couvercle du détendeur doit toujours être en place, sauf lorsque la bouteille est utilisée ou qu'elle est reliée pour usage ultérieur.
- Utiliser les équipements corrects, les bonnes procédures et suffisamment de personnes pour soulever et déplacer les bouteilles.
- Lire et suivre les instructions sur les bouteilles de gaz comprimé, l'équipement connexe et le dépliant P-1 de la CGA (Compressed Gas Association) mentionné dans les principales normes de sécurité.

2-3. Dangers supplémentaires en relation avec l'installation, le fonctionnement et la maintenance



Risque D'INCENDIE OU D'EXPLOSION.

- Ne pas placer l'appareil sur, au-dessus ou à proximité de surfaces inflammables.
- Ne pas installer l'appareil à proximité de produits inflammables.
- Ne pas surcharger l'installation électrique – s'assurer que l'alimentation est correctement dimensionnée et protégée avant de mettre l'appareil en service.

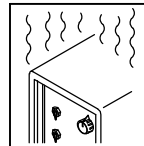

L'EMPLOI EXCESSIF peut SURCHAUFFER L'ÉQUIPEMENT.

- Prévoir une période de refroidissement ; respecter le cycle opératoire nominal.
- Réduire le courant ou le facteur de marche avant de poursuivre le soudage.
- Ne pas obstruer les passages d'air du poste.



LA CHUTE DE L'ÉQUIPEMENT peut provoquer des blessures.

- Utiliser l'anneau de levage uniquement pour soulever l'appareil, NON PAS les chariots, les bouteilles de gaz ou tout autre accessoire.
- Utiliser un équipement de levage de capacité suffisante pour lever l'appareil.
- En utilisant des fourches de levage pour déplacer l'unité, s'assurer que les fourches sont suffisamment longues pour dépasser du côté opposé de l'appareil.
- Tenir l'équipement (câbles et cordons) à distance des véhicules mobiles lors de toute opération en hauteur.
- Suivre les consignes du Manuel des applications pour l'équation de levage NIOSH révisée (Publication N°94-110) lors du levage manuel de pièces ou équipements lourds.

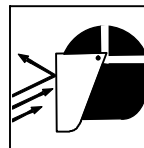

LES ÉTINCELLES PROJETÉES peuvent provoquer des blessures.

- Porter un écran facial pour protéger le visage et les yeux.
- Affûter l'électrode au tungstène uniquement à la meuleuse dotée de protecteurs. Cette manœuvre est à exécuter dans un endroit sûr lorsque l'on porte l'équipement homologué de protection du visage, des mains et du corps.
- Les étincelles risquent de causer un incendie – éloigner toute substance inflammable.

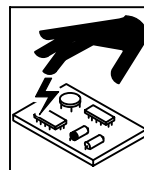

LES CHARGES ÉLECTROSTATIQUES peuvent endommager les circuits imprimés.

- Établir la connexion avec la barrette de terre avant de manipuler des cartes ou des pièces.
- Utiliser des pochettes et des boîtes antistatiques pour stocker, déplacer ou expédier des cartes de circuits imprimés.



Les PIÈCES MOBILES peuvent causer des blessures.

- Ne pas s'approcher des organes mobiles.
- Ne pas s'approcher des points de coincement tels que des rouleaux de commande.



LES FILS DE SOUDAGE peuvent provoquer des blessures.

- Ne pas appuyer sur la gâchette avant d'en avoir reçu l'instruction.
- Ne pas diriger le pistolet vers soi, d'autres personnes ou toute pièce mécanique en engageant le fil de soudage.



L'EXPLOSION DE LA BATTERIE peut provoquer des blessures.

- Ne pas utiliser l'appareil de soudage pour charger des batteries ou faire démarrer des véhicules à l'aide de câbles de démarrage, sauf si l'appareil dispose d'une fonctionnalité de charge de batterie destinée à cet usage.



Les PIÈCES MOBILES peuvent causer des blessures.

- S'abstenir de toucher des organes mobiles tels que des ventilateurs.
- Maintenir fermés et verrouillés les portes, panneaux, recouvrements et dispositifs de protection.
- Lorsque cela est nécessaire pour des travaux d'entretien et de dépannage, faire retirer les portes, panneaux, recouvrements ou dispositifs de protection uniquement par du personnel qualifié.
- Remettre les portes, panneaux, recouvrements ou dispositifs de protection quand l'entretien est terminé et avant de rebrancher l'alimentation électrique.

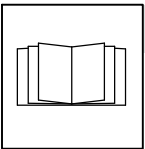

LIRE LES INSTRUCTIONS.

- Lire et appliquer les instructions sur les étiquettes et le Mode d'emploi avant l'installation, l'utilisation ou l'entretien de l'appareil. Lire les informations de sécurité au début du manuel et dans chaque section.
- N'utiliser que les pièces de rechange recommandées par le constructeur.
- Effectuer l'entretien en respectant les manuels d'utilisation, les normes industrielles et les codes nationaux, d'état et locaux.

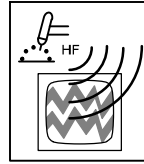

LE RAYONNEMENT HAUTE FRÉQUENCE (H.F.) risque de provoquer des interférences.

- Le rayonnement haute fréquence (H.F.) peut provoquer des interférences avec les équipements de radio-navigation et de communication, les services de sécurité et les ordinateurs.

- Demander seulement à des personnes qualifiées familiarisées avec des équipements électroniques de faire fonctionner l'installation.
- L'utilisateur est tenu de faire corriger rapidement par un électricien qualifié les interférences résultant de l'installation.
- Si le FCC signale des interférences, arrêter immédiatement l'appareil.
- Effectuer régulièrement le contrôle et l'entretien de l'installation.
- Maintenir soigneusement fermés les portes et les panneaux des sources de haute fréquence, maintenir les éclateurs à une distance correcte et utiliser une terre et un blindage pour réduire les interférences éventuelles.

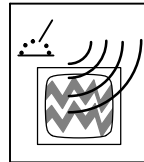

LE SOUDAGE À L'ARC risque de provoquer des interférences.

- L'énergie électromagnétique risque de provoquer des interférences pour l'équipement électronique sensible tel que les ordinateurs et l'équipement commandé par ordinateur tel que les robots.
- Veiller à ce que tout l'équipement de la zone de soudage soit compatible électromagnétiquement.
- Pour réduire la possibilité d'interférence, maintenir les câbles de soudage aussi courts que possible, les grouper, et les poser aussi bas que possible (ex. par terre).
- Veiller à souder à une distance de 100 mètres de tout équipement électronique sensible.
- Veiller à ce que ce poste de soudage soit posé et mis à la terre conformément à ce mode d'emploi.
- En cas d'interférences après avoir pris les mesures précédentes, il incombe à l'utilisateur de prendre des mesures supplémentaires telles que le déplacement du poste, l'utilisation de câbles blindés, l'utilisation de filtres de ligne ou la pose de protecteurs dans la zone de travail.

2-4. Proposition californienne 65 Avertissements



Les équipements de soudage et de coupage produisent des fumées et des gaz qui contiennent des produits chimiques dont l'État de Californie reconnaît qu'ils provoquent des malformations congénitales et, dans certains cas, des cancers. (Code de santé et de sécurité de Californie, chapitre 25249.5 et suivants)



Ce produit contient des produits chimiques, notamment du plomb, dont l'État de Californie reconnaît qu'ils provoquent des cancers, des malformations congénitales ou d'autres problèmes de procréation. *Se laver les mains après utilisation.*

2-5. Principales normes de sécurité

Safety in Welding, Cutting, and Allied Processes, ANSI Standard Z49.1, is available as a free download from the American Welding Society at <http://www.aws.org> or purchased from Global Engineering Documents (phone: 1-877-413-5184, website: www.global.ihs.com).

Safe Practices for the Preparation of Containers and Piping for Welding and Cutting, American Welding Society Standard AWS F4.1, from Global Engineering Documents (phone: 1-877-413-5184, website: www.global.ihs.com).

Safe Practices for Welding and Cutting Containers that have Held Combustibles, American Welding Society Standard AWS A6.0, from Global Engineering Documents (phone: 1-877-413-5184, website: www.global.ihs.com).

National Electrical Code, NFPA Standard 70, from National Fire Protection Association, Quincy, MA 02269 (phone: 1-800-344-3555, website: www.nfpa.org and www.sparky.org).

Safe Handling of Compressed Gases in Cylinders, CGA Pamphlet P-1, from Compressed Gas Association, 14501 George Carter Way, Suite 103, Chantilly, VA 20151 (phone: 703-788-2700, website: www.cganet.com).

Safety in Welding, Cutting, and Allied Processes, CSA Standard W117.2, from Canadian Standards Association, Standards Sales, 5060

Spectrum Way, Suite 100, Ontario, Canada L4W 5NS (phone: 800-463-6727, website: www.csa-international.org).

Safe Practice For Occupational And Educational Eye And Face Protection, ANSI Standard Z87.1, from American National Standards Institute, 25 West 43rd Street, New York, NY 10036 (phone: 212-642-4900, website: www.ansi.org).

Standard for Fire Prevention During Welding, Cutting, and Other Hot Work, NFPA Standard 51B, from National Fire Protection Association, Quincy, MA 02269 (phone: 1-800-344-3555, website: www.nfpa.org).

OSHA, Occupational Safety and Health Standards for General Industry, Title 29, Code of Federal Regulations (CFR), Part 1910, Subpart Q, and Part 1926, Subpart J, from U.S. Government Printing Office, Superintendent of Documents, P.O. Box 371954, Pittsburgh, PA 15250-7954 (phone: 1-866-512-1800) (there are 10 OSHA Regional Offices—phone for Region 5, Chicago, is 312-353-2220, website: www.osha.gov).

Applications Manual for the Revised NIOSH Lifting Equation, The National Institute for Occupational Safety and Health (NIOSH), 1600 Clifton Rd, Atlanta, GA 30333 (phone: 1-800-232-4636, website: www.cdc.gov/NIOSH).

2-6. Informations relatives aux CEM

Le courant électrique qui traverse tout conducteur génère des champs électromagnétiques (CEM) à certains endroits. Le courant de soudage crée un CEM autour du circuit et du matériel de soudage. Les CEM peuvent créer des interférences avec certains implants médicaux comme des stimulateurs cardiaques. Des mesures de protection pour les porteurs d'implants médicaux doivent être prises: Limiter par exemple tout accès aux passants ou procéder à une évaluation des risques individuels pour les soudeurs. Tous les soudeurs doivent appliquer les procédures suivantes pour minimiser l'exposition aux CEM provenant du circuit de soudage:

1. Rassembler les câbles en les torsadant ou en les attachant avec du ruban adhésif ou avec une housse.
2. Ne pas se tenir au milieu des câbles de soudage. Disposer les câbles d'un côté et à distance de l'opérateur.
3. Ne pas courber et ne pas entourer les câbles autour de votre corps.

4. Maintenir la tête et le torse aussi loin que possible du matériel du circuit de soudage.
5. Connecter la pince sur la pièce aussi près que possible de la soudure.
6. Ne pas travailler à proximité d'une source de soudage, ni s'asseoir ou se pencher dessus.
7. Ne pas souder tout en portant la source de soudage ou le dévidoir.

En ce qui concerne les implants médicaux :

Les porteurs d'implants doivent d'abord consulter leur médecin avant de s'approcher des opérations de soudage à l'arc, de soudage par points, de gougeage, du coupage plasma ou de chauffage par induction. Si le médecin approuve, il est recommandé de suivre les procédures précédentes.

SECTION 3 – SPECIFICATIONS

☞ Appearance of actual unit may vary from unit shown in manual.

3-1. Specifications

Input Power	Rated Welding Output	Amperage/Voltage Range DC	Max Open Circuit Voltage DC	IP Rating	Amperes Input At Rated Load Output 60 Hz, Three-Phase						Input kVA	Input KW
					208 V	230 V	380 V	400V	460 V	575 V		
Three Phase	300 A @ 32 V DC, 60% Duty Cycle	10-300 A In CC Mode	80 V In CC Mode	IP 23C**	33.3 (0-1A*)	30.1 (0-1A*)	18.0 (0-1A*)	17.1 (0-1A*)	14.8 (0-1A*)	12.0 (0-1A*)	11.9 (0.2*)	11.4 (0.4*)
	300 A @ 29 V DC, 60% Duty Cycle	10-44 V In CV mode	80 V In CV Mode		30.5 (0-1A*)	27.6 (0-1A*)	16.5 (0-1A*)	15.7 (0-1A*)	13.6 (0-1A*)	10.9 (0-1A*)	10.9 (0.2*)	10.4 (0.4*)
	225 A @ 29 V DC, 100% Duty Cycle	10-300 A In CC Mode	80 V In CC Mode		22.8 (0-1A*)	20.6 (0-1A*)	12.4 (0-1A*)	11.8 (0-1A*)	10.3 (0-1A*)	8.6 (0-1A*)	8.3 (0.2*)	7.8 (0.4*)
	220 A @ 25 V DC, 100% Duty Cycle	10-44 V In CV mode	80 V In CV Mode		19.5 (0-1A*)	17.6 (0-1A*)	10.5 (0-1A*)	10.0 (0-1A*)	8.7 (0-1A*)	7.7 (0-1A*)	7.2 (0.2*)	6.7 (0.4*)

*While idling: Input amperage fluctuates while idling and is always less than one ampere. Use one ampere for power efficiency calculations.

**This equipment is designed for outdoor use. It may be stored, but is not intended to be used outside during precipitation unless sheltered.

3-2. Dimensions And Weight

Hole Layout Dimensions	
A	17-3/32 in. (434 mm)
B	17-3/8 in. (441 mm)
C	19-3/32 in. (485 mm)
D	16-3/32 in. (409 mm)
E	1/2 in. (13 mm)
Weight	
112 lb (51 kg) Net 134 lb (61 kg) Ship	

243 893-A

SECTION 4 – INSTALLATION

4-1. Serial Number And Rating Label Location

The serial number and rating information for this product is located on the back. Use rating label to determine input power requirements and/or rated output. For future reference, write serial number in space provided on back cover of this manual.

4-2. Selecting A Location

Movement

OR

Tipping **Do not move or operate unit where it could tip.**

Location **Special installation may be required where gasoline or volatile liquids are present – see NEC Article 511 or CEC Section 20.**

Do not stack units. Beware of tipping.

1 Lifting Forks
Use lifting forks to move unit.
Extend forks beyond opposite side of unit.

2 Hand Cart
Use cart or similar device to move unit.

3 Line Disconnect Device
Locate unit near correct input power supply.

loc_2 3/96 -243 893-A

4-3. Proper Ring Terminal Connection To Volt Sense Lead

Front View

SHIELD
BLACK

Tools Needed:

If volt sense lead is cut or broken at end with ring terminal, be sure that new ring terminal is connected as shown.

DO NOT allow braided shield to touch center conductor or workpiece.

1 Jacket

2 Insulated Tape Or Heat-Shrink Tubing

3 Braided Shield

Cut off shield at end of jacket.

4 Inner Core

5 Center Conductor

6 Ring Terminal

208 810

4-4. Connecting Volt Sense Lead And Work Cable To Clamp

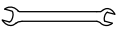
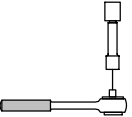

Tools Needed:

-  1/2 in.
-  1/2 in.

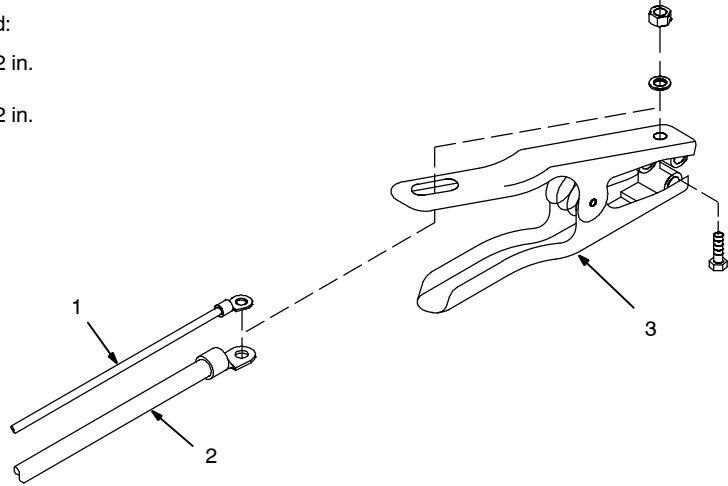

- 1 Volt Sense Lead
- 2 Work Cable
- 3 Clamp

 *Be sure that volt sense lead ring terminal is on top of work cable ring terminal when connecting to clamp.*

Connect volt sense lead and work cable to clamp.

805 030-A

4-5. Connecting To Weld Terminals



 *If using an electrode negative (straight polarity) process, the volt sense lead must be connected to the work.*

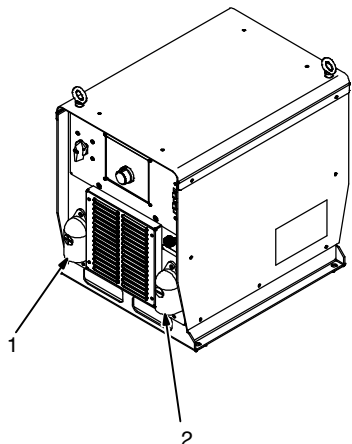

1
2

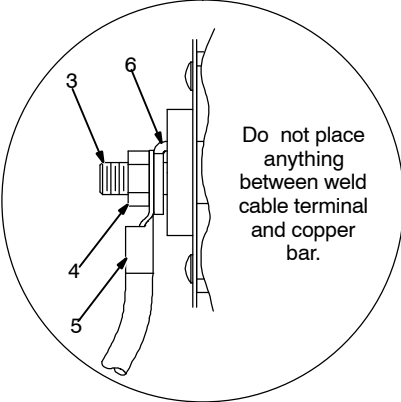

3
4
5
6

Do not place anything between weld cable terminal and copper bar.

Correct Installation

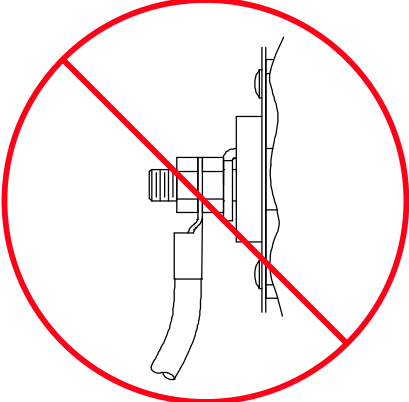

Incorrect Installation

Tools Needed:

-  3/4 in. (19 mm)

 **Turn off power before connecting to weld output terminals.**

 **Failure to properly connect weld cables may cause excessive heat and start a fire, or damage your machine.**

Determine total cable length in weld circuit (both positive and negative cables combined) and maximum welding amperes. See Section 4-6 to select proper

cable size.

- 1 Positive (+) Weld Output Terminal
- 2 Negative (-) Weld Output Terminal

Connect positive weld cable to Positive (+) weld terminal and negative (-) cable to Negative weld terminal.

- 3 Weld Output Terminal
- 4 Supplied Weld Output Terminal Nut
- 5 Weld Cable Terminal

- 6 Copper Bar

Remove supplied nut from weld output terminal. Slide weld cable terminal onto weld output terminal and secure with nut so that weld cable terminal is tight against copper bar. **Do not place anything between weld cable terminal and copper bar. Make sure that the surfaces of the weld cable terminal and copper bar are clean.**

243 893-A / 803 778-A

4-6. Selecting Weld Cable Sizes*

NOTICE – The Total Cable Length in Weld Circuit (see table below) is the combined length of both weld cables. For example, if the power source is 100 ft (30 m) from the workpiece, the total cable length in the weld circuit is 200 ft (2 cables x 100 ft). Use the 200 ft (60 m) column to determine cable size.

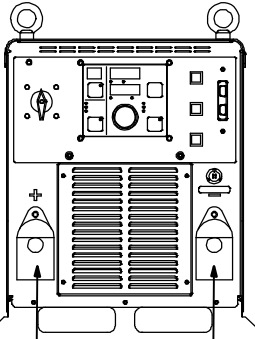
 <p>Weld Output Terminals</p> <p>⚠ Turn off power before connecting to weld output terminals.</p> <p>⚠ Do not use worn, damaged, undersized, or poorly spliced cables.</p>	Weld Cable Size** and Total Cable (Copper) Length in Weld Circuit Not Exceeding***									
	Welding Amperes	100 ft (30 m) or Less	150 ft (45 m)	200 ft (60 m)	250 ft (70 m)	300 ft (90 m)	350 ft (105 m)	400 ft (120 m)		
		10 – 60% Duty Cycle AWG (mm ²)	60 – 100% Duty Cycle AWG (mm ²)	10 – 100% Duty Cycle AWG (mm ²)						
 <p>Positive +</p> <p>Negative -</p> <p>Ref. 803 677-A</p>	100	4 (20)	4 (20)	4 (20)	3 (30)	2 (35)	1 (50)	1/0 (60)	1/0 (60)	
	150	3 (30)	3 (30)	2 (35)	1 (50)	1/0 (60)	2/0 (70)	3/0 (95)	3/0 (95)	
	200	3 (30)	2 (35)	1 (50)	1/0 (60)	2/0 (70)	3/0 (95)	4/0 (120)	4/0 (120)	
	250	2 (35)	1 (50)	1/0 (60)	2/0 (70)	3/0 (95)	4/0 (120)	2 ea. 2/0 (2x70)	2 ea. 2/0 (2x70)	
	300	1 (50)	1/0 (60)	2/0 (70)	3/0 (95)	4/0 (120)	2 ea. 2/0 (2x70)	2 ea. 3/0 (2x95)	2 ea. 3/0 (2x95)	
	350	1/0 (60)	2/0 (70)	3/0 (95)	4/0 (120)	2 ea. 2/0 (2x70)	2 ea. 3/0 (2x95)	2 ea. 3/0 (2x95)	2 ea. 4/0 (2x120)	
	400	1/0 (60)	2/0 (70)	3/0 (95)	4/0 (120)	2 ea. 2/0 (2x70)	2 ea. 3/0 (2x95)	2 ea. 4/0 (2x120)	2 ea. 4/0 (2x120)	
	500	2/0 (70)	3/0 (95)	4/0 (120)	2 ea. 2/0 (2x70)	2 ea. 3/0 (2x95)	2 ea. 4/0 (2x120)	3 ea. 3/0 (3x95)	3 ea. 3/0 (3x95)	
600	3/0 (95)	4/0 (120)	2 ea. 2/0 (2x70)	2 ea. 3/0 (2x95)	2 ea. 4/0 (2x120)	3 ea. 3/0 (3x95)	3 ea. 4/0 (3x120)	3 ea. 4/0 (3x120)		

* This chart is a general guideline and may not suit all applications. If cable overheats, use next size larger cable.

**Weld cable size (AWG) is based on either a 4 volts or less drop or a current density of at least 300 circular mils per ampere.
() = mm² for metric use

***For distances longer than those shown in this guide, call a factory applications rep. at 920-735-4505 (Miller) or 1-800-332-3281 (Hobart)

Ref. S-0007-G 2009-08

4-7. Arranging Welding Cables To Reduce Welding Circuit Inductance (Suitcase Feeder)



Bad

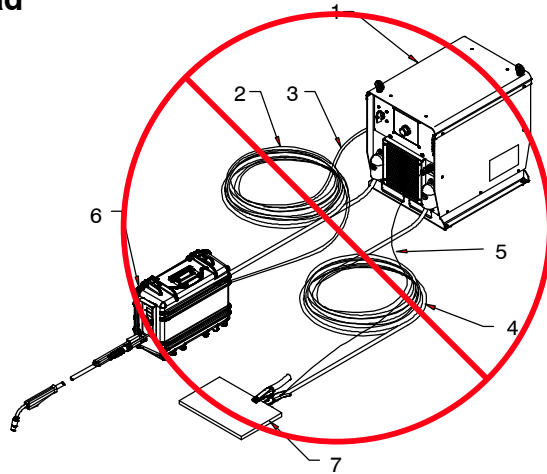

- DO NOT coil cables
- DO NOT share work clamps (no more than 1 machine per clamp)
- DO NOT tangle cables from different machines
- DO NOT splice weld cables
- DO NOT allow volt sense lead braided shield to touch center conductor or workpiece

Ideal

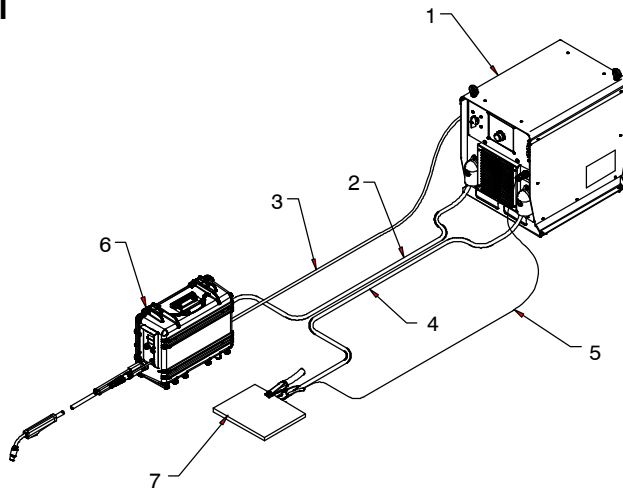

- Use shortest cables possible for the job
- Use proper sized work clamp and weld cables to accommodate peak amperages
- Separate volt sense lead and feeder control cable from weld cables
- Place weld cables together if possible
- Connect work clamp as close to welding arc as possible

- 1 Welding Power Source
- 2 Electrode Cable
- 3 Extension Cable (Optional)
- 4 Work Cable
- 5 Volt Sense Lead
- 6 Wire Feeder
- 7 Workpiece

The method used to arrange cables has a significant affect on welding properties. As an example, RMD welding process can produce high welding circuit inductance depending on cable length and arrangement. This can result in limited current rise during droplet transfer into the welding puddle.

The electrode sense lead is contained in the feeder control cable and is enabled for all processes. The work sense lead connects to the welding power source 4-pin connector located above the negative output terminal. This work sense lead automatically compensates for work cable voltage drop when connected to the welding power source.

Do not coil excess cables. Use cables that are the appropriate length for the application. Whenever using long weld cables [longer than 50 ft (15 m)] try to arrange positive and negative weld cables together to reduce the magnetic field surrounding the cables. Avoid coupling the feeder and work sense leads with the weld cables.

4-8. Voltage Sensing Lead And Work Cable Connections For Multiple Welding Arcs (Suitcase Feeder)

A. Bad Setup

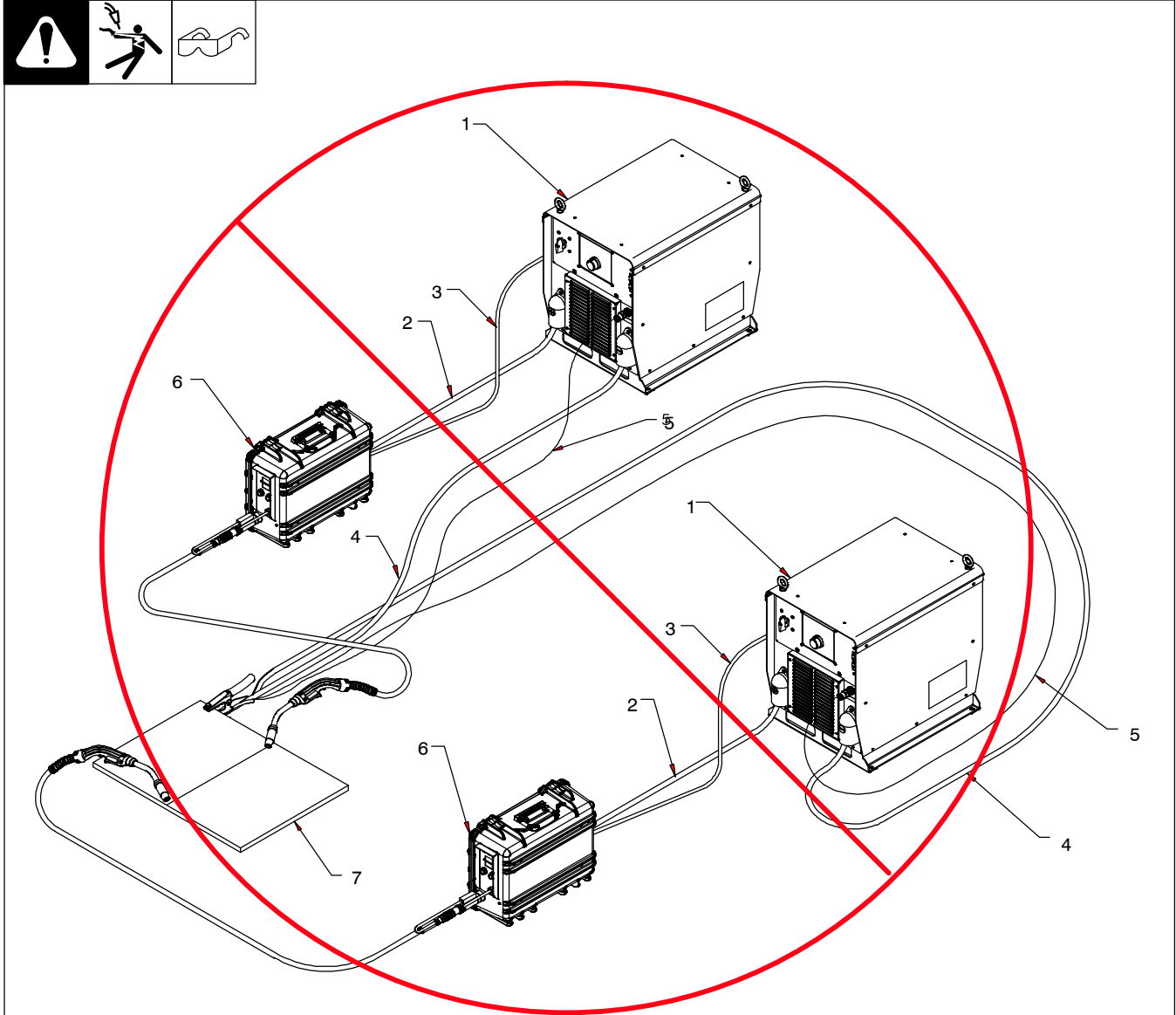

243 906-A

- 1 Welding Power Source
- 2 Electrode Cable
- 3 Extension Cable (Optional)
- 4 Work Cable
- 5 Voltage Sensing Lead
- 6 Wire Feeder

- 7 Workpiece

This arrangement is a bad setup due to sensing leads being directly in the current flow path of the welding arc. Interaction between welding circuits will affect voltage feedback in the workpiece. The voltage drop

across the workpiece will not be measured correctly for the voltage feedback signal. Voltage feedback to the welding power sources will not be correct at either sense lead and result in poor arc starts and arc quality.

B. Ideal Setup

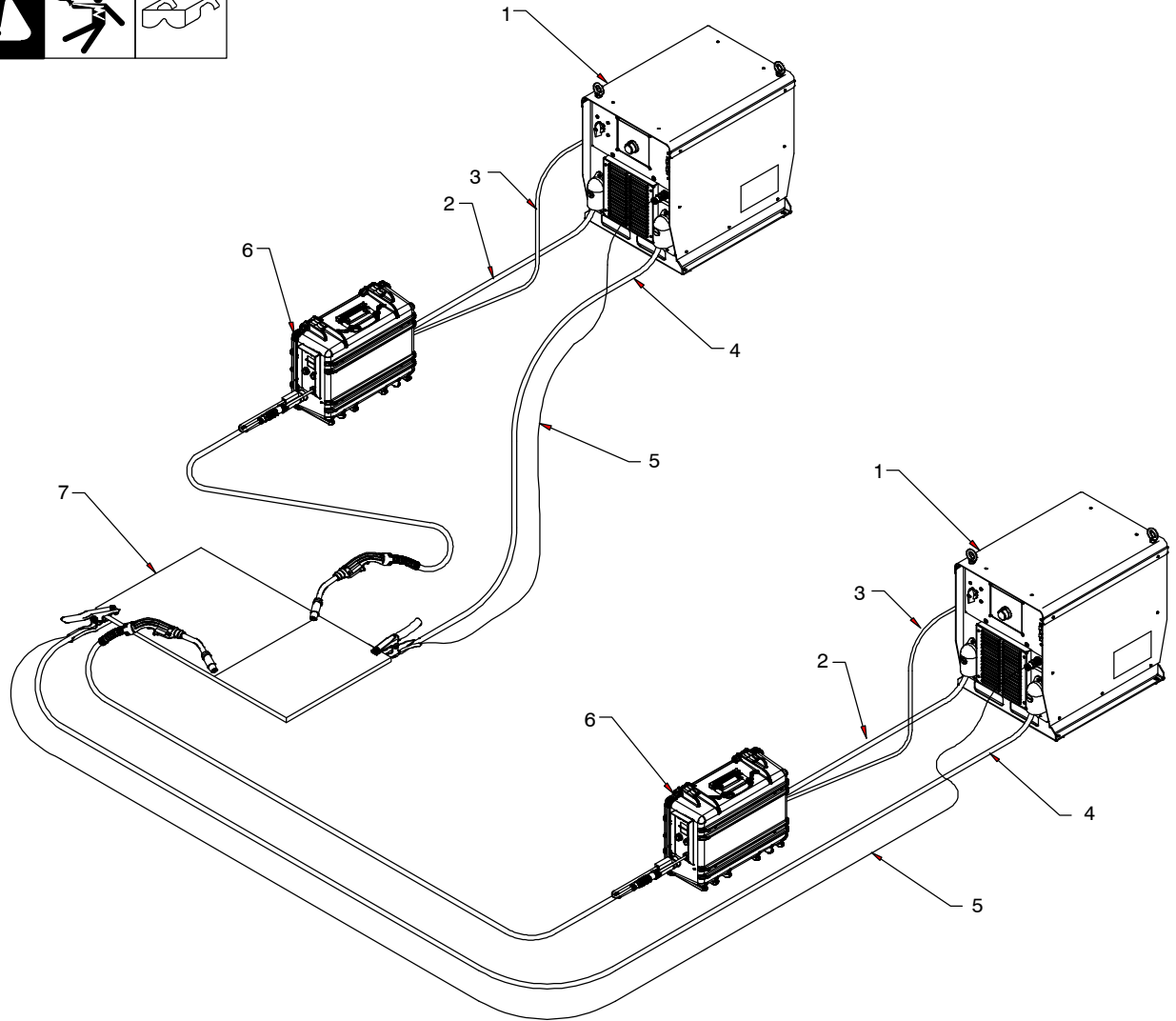

243 908-A

- 1 Welding Power Source
- 2 Electrode Cable
- 3 Extension Cable (Optional)
- 4 Work Cable
- 5 Voltage Sensing Lead

- 6 Wire Feeder
- 7 Workpiece

This arrangement is a better setup for supporting separate voltage feedback to

the welding power sources. The most accurate voltage sensing may not be achieved due to voltage drops in the workpiece. This may require compensation in the welding parameters.

4-9. Rear Panel Receptacles And Supplementary Protectors

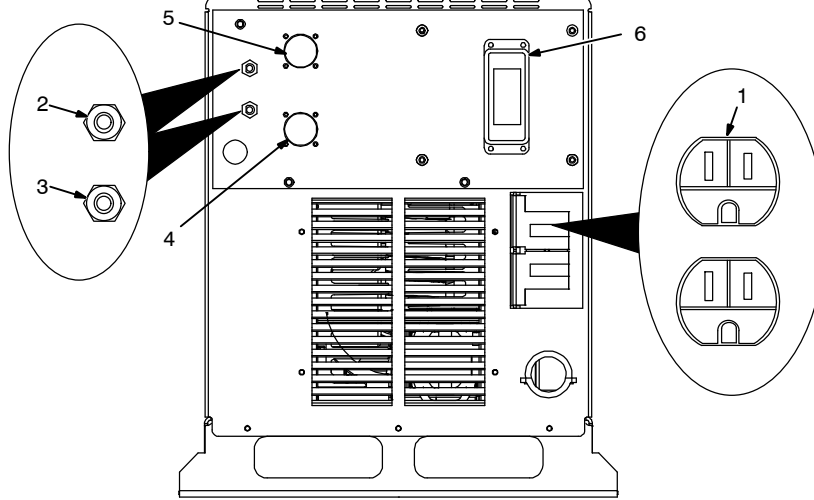

Ref. 803 676-A

1 115 V 10 A AC Receptacle RC2
Receptacle supplies 60 Hz single-phase power. Maximum output from RC2 is limited by supplementary protector CB1 to 10 amps.

2 Supplementary Protector CB1

3 Supplementary Protector CB2

CB1 protects 115 volt receptacle RC2 from overload. If CB1 opens, RC2 does not work.

CB2 is rated at 15 amperes and protects the wire feeder from overload. If CB2 opens, the wire feeder does not work.

 Press button to reset breaker. If breaker continue to open, contact a Factory Authorized Service Agent.

4 Wire Feed/Gas Receptacle RC8

Use receptacle to connect PipePro interconnect cable to power source (see

Sections 4-11 and 8 for additional information).

5 Peripheral Receptacle RC25

Receptacle provides connection to the water flow switch (see Section 4-10).

6 Interface Receptacle RC72

Use receptacle to connect PipePro interconnect cable (see Section 8 for additional information).

4-10. Peripheral Receptacle Functions

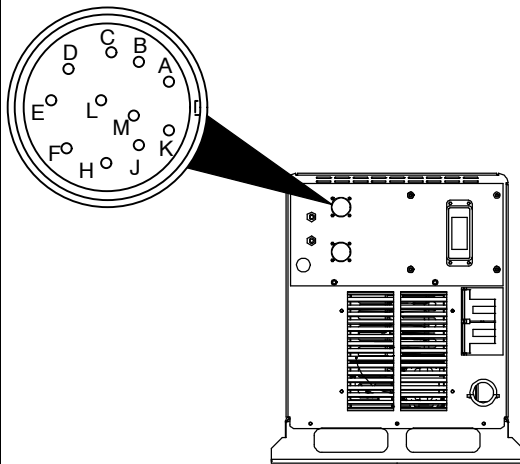

Ref. 803 675-A

Function	Socket	Socket Information
	A	Not used.
	B	Not used.
	C*	Circuit common.
	D	Not used.
Coolant Flow Switch Input Signal	E	Contact closure to F indicates coolant flow switch is closed and recirculating coolant system is operational.
	F*	Circuit common.
	H	Not used.
	J	Not used.
	K	Not used.
	L	Not used.
	M	Not used.

*Circuit common is same electrical reference point.

Note: A customer supplied matching amphenol plug, factory Part No. 194 847, [Amphenol Part No. 97-3106A-20-33P(B)(621) and strain relief clamp 97-3057-12(0621)] is required to use peripheral receptacle.

4-11. Motor Control Receptacle Functions

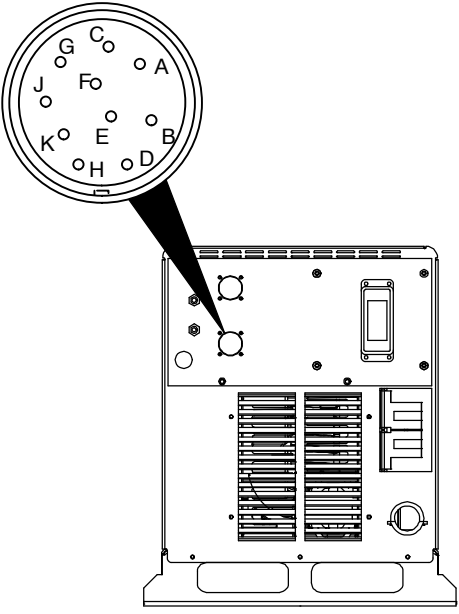
	Socket	Socket Information
	A	Not used.
	B	+40 volts dc.
	C	Not used.
	D	+40 volts dc return.
	E	Not used.
	F	Not used.
	G	Electrode sense.
	H	Not used.
	J	Not used.
<p style="text-align: center;">Ref. 803 675-A</p>	K	Not used.

4-12. Remote 14 Receptacle Information

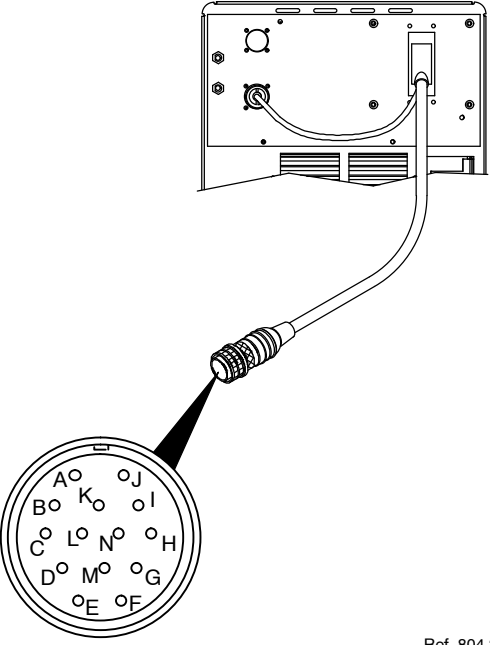
	Socket	Socket Information
	A	+40 volts dc with respect to socket G.
	G	Circuit common for +40 volts dc circuit.
	B	Contact closure to socket K completes contactor control circuit.
	K	Contact closure to socket B completes contactor control circuit.
	C	+10 volts dc input from power source to wire feeder with respect to socket D.
	D	Remote volt control circuit common.
	E	0 to +10 volts dc remote volt/trim signal from wire feeder to power source with respect to socket D.
	H	Voltage feedback; 0 to +10 volts dc, 1 volt per 10 arc volts.
	F	Current feedback; 0 to +10 volts dc, 1 volt per 100 amperes.
	M	0 to +10 volts dc remote WFS signal from wire feeder to power source with respect to socket N, 1 volt per 100 IPM. When doing Stick (SMAW) or TIG (GTAW) welding, the 0 to +10 volts dc is a scale of the power source front panel setting.
<p style="text-align: center;">Ref. 804 374-A</p>	N	Remote WFS control circuit common.
	I	Remote process select A.
	J	Remote process select B.
	L	Electrode sense.

4-14. Connecting 3-Phase Input Power

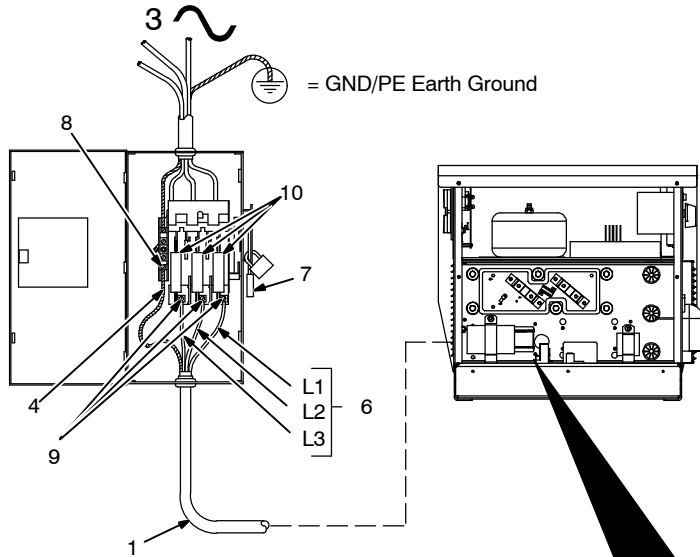

WARNING



ELECTRIC SHOCK can kill; SIGNIFICANT DC VOLTAGE exists after removal of input power.

- Always wait 5 minutes after power is turned off before working on unit.
- Check input capacitor voltage, and be sure it is near 0 before touching any parts.



Read Owner's Manual.

Three-Phase Input Connection

Route input power cable through tubing inside unit.

Route ground conductor through current transducer to ground terminal.

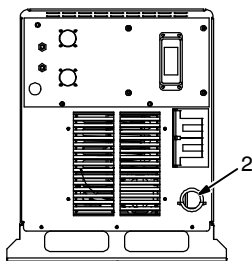
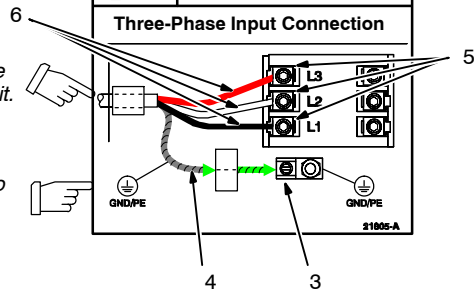

Tools Needed:



4-14. Connecting 3-Phase Input Power (Continued)



⚠ Turn Off welding power source, and check voltage on input capacitors according to Section 8-4 before proceeding.

⚠ Installation must meet all National and Local Codes – have only qualified persons make this installation.

⚠ Disconnect and lockout/tagout input power before connecting input conductors from unit. Follow established procedures regarding the installation and removal of lockout/tagout devices.

⚠ Make input power connections to the welding power source first.

⚠ Always connect green or green/yellow conductor to supply grounding terminal first, and never to a line terminal.

☞ The Auto-Line circuitry in this unit automatically links the power source to the primary voltage being applied. Check input voltage available at site. This unit can be connected to any input power between 208 and 575 VAC without relinking the power source.

See rating label on unit and check input voltage available at site.

1 Input Power Conductors (Customer Supplied Cord)

Select size and length of conductors using Section 4-13. Conductors must comply with national, state, and local electrical codes. If applicable, use lugs of proper amperage capacity and correct hole size.

Welding Power Source Input Power Connections

2 Strain Relief

Install strain relief of proper size for unit and input conductors. Route conductors (cord) through strain relief and tighten screws.

3 Welding Power Source Grounding Terminal

4 Green Or Green/Yellow Grounding Conductor

Route green or green/yellow grounding conductor through current transducer and connect to welding power source grounding terminal first.

5 Welding Power Source Line Terminals

6 Input Conductors L1 (U), L2 (V) And L3 (W)

Connect input conductors L1 (U), L2 (V) and L3 (W) to welding power source line terminals.

Reinstall side panel onto welding power source.

Disconnect Device Input Power Connections

7 Disconnect Device (switch shown in the OFF position)

8 Disconnect Device (Supply) Grounding Terminal

9 Disconnect Device Line Terminals

Connect green or green/yellow grounding conductor to disconnect device grounding terminal first.

Connect input conductors L1 (U), L2 (V), and L3 (W) to disconnect device line terminals.

10 Over-Current Protection

Select type and size of over-current protection using Section 4-13 (fused disconnect switch shown).

Close and secure door on line disconnect device. Follow established lockout/tagout procedures to put unit in service.

Notes

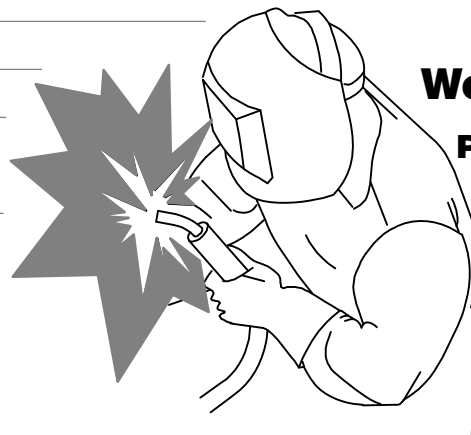

Work like a Pro!

Pros weld and cut safely. Read the safety rules at the beginning of this manual.

SECTION 5 – OPERATION

5-1. Operational Terms

The following is a list of terms and their definitions as they apply to this interface unit:

General Terms:

Adjust	Control knob used to change or set parameters and functions.
Amps	Indicates average amperage while welding and 3 seconds hold value at end of weld.
Arc Adjust	Term used to represent arc length adjustments in RMD-Pro programs. Increasing Arc Adjust increases the actual arc length. Likewise, decreasing arc adjust shortens arc length. Arc Adjust is replaced by volts in MIG programs.
Arc Control	Pressing this button will allow setting of inductance in MIG mode and sharp arc in RMD-Pro. Also, this button allows setting dig in stick mode.
Arc Length	Distance from end of wire electrode to workpiece.
Flux Cored Arc Welding	Flux cored arc welding (FCAW) is a continuous electrode that is fed into the arc and depends on shielding gas from either an external source or is generated from the decomposition of gas forming ingredients contained in the electrode's core.
Gas Type	Selection of shielding gas being used in application.
Inductance	In short circuit GMAW welding, an increase in inductance will decrease the number of short circuit transfers per second (provided no other changes are made) and increase the arc-on time. The increased arc-on time makes the welding puddle more fluid.
MIG	CV weld process with individual settings of voltage and wire speed.
Process	A selection made for MIG, Pulse, Pro-pulse, RMD-Pro, Flux Core (FCAW), Stick, and Lift-TIG.
Process Set Up	Selection procedure for entering program.
Program	Eight active slots for selection of various processes, wire types, and parameters.
Program Load	Enters selected program information (process, wire type, gas, etc.) into program slot (1-8).
Pro-pulse	Pulse process utilizing constant current ramps with constant voltage control of peaks and backgrounds. Adaptive response is controlled by peak and minimum current levels. Benefits are shorter arc lengths, better puddle control, more tolerant of tip-to-work variation, less audible noise, no arc wandering, allows weld to fill in at toes increasing travel speed and deposition, and more tolerant to poor fit up and gaps.
Pulse	Conventional pulse program using peak, background, pulse width, frequency, and peak voltage as factory taught data. Adaptive method is controlled by frequency adjustment.
RMD-Pro	RMD-Pro refers to Regulated Metal Deposition. A precisely controlled short-circuit transfer. Benefits of RMD-Pro are well suited to root pass welding on pipe, improves gap filling and spatter reduction. Provides less heat input into workpiece, minimizes distortion and allows use of larger diameter wire on thin gauge materials.
Sharp Arc	In RMD-Pro this control will affect the arc in much the same way as inductance.
Start	Provides voltage/arc adjust, wire feed rate, and time value for modified arc starts [which is only adjustable with the optional PDA with PipePro Program Management software (PipeProMgr)].
Stick	Stick (SMAW) welding uses a flux covered consumable electrode that produces a shielding gas and slag to shield the arc and molten weld puddle.
Synergic	Synergic refers to the unit's ability to use preprogrammed parameters to automatically adjust various weld parameters at any specific wire feed speed setting.
TIG	TIG (GTAW) welding uses a non-consumable tungsten electrode and shielding gas to produce a strong, clean, high quality weld.
Volts	Preset voltage in MIG mode at idle, actual voltage while welding, and 3 seconds hold value at end of weld.
Wire Type	Selection of wire type by alloys and classification.
WFS	Term used to represent wire feed speed. In MIG mode, wire feed setting is independent of voltage setting. In RMD-Pro adjusting wire feed speed also increases power level on wire electrode (one knob control).

5-2. Front Panel Controls (See Section 5-3)

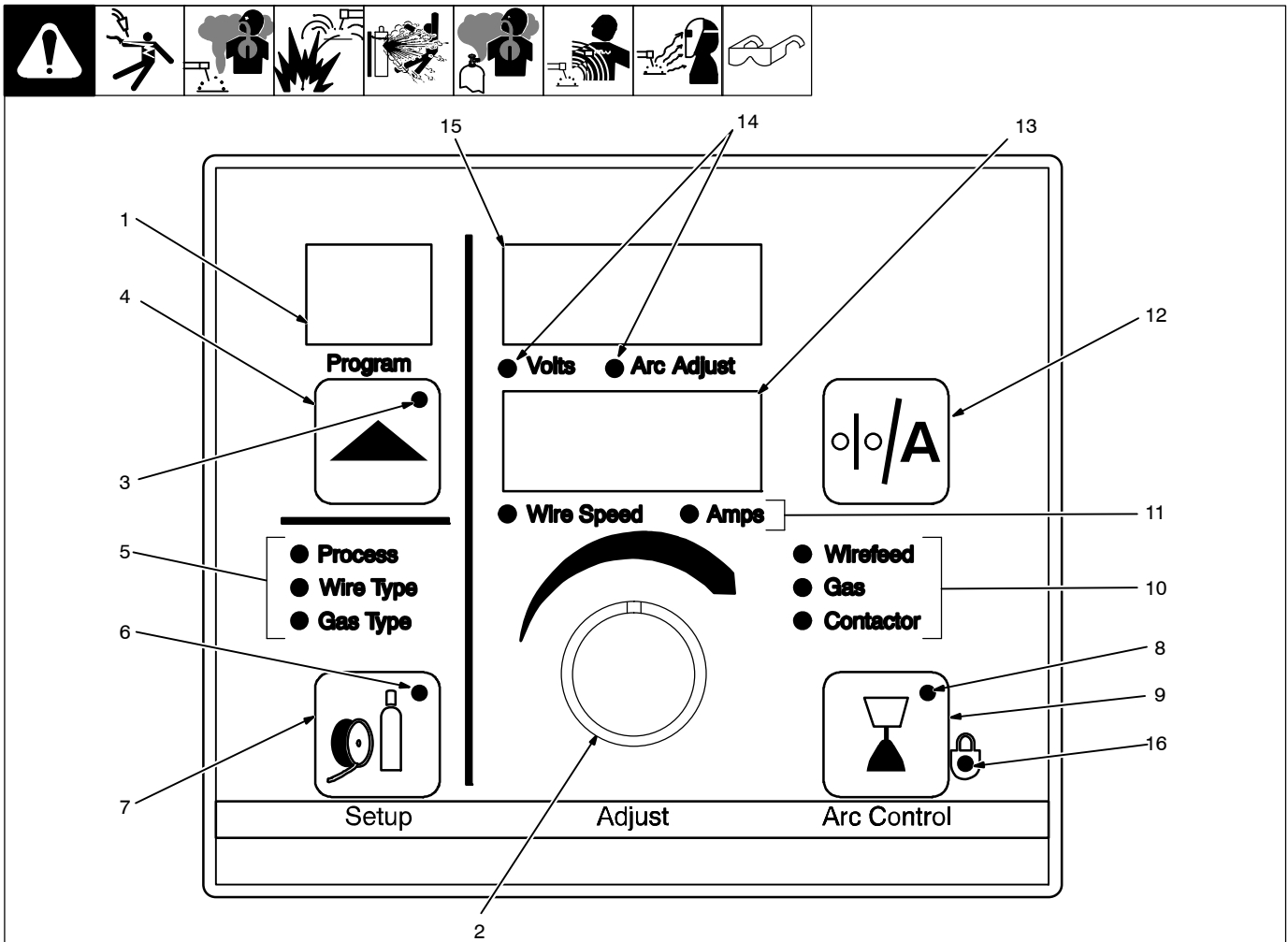

☞ When an LED is lit, it means the related function is active.

200 410

1 Program Display

Displays the number of the active program.

2 Adjust Knob

Turn the Adjust knob to change program number, Setup, Arc Control, and weld parameters.

Panel/Remote amperage control is set for each individual program. When set to remote, the control range is from minimum to the value set on the front panel.

3 Program Pushbutton LED

The LED lights when the Program Pushbutton is active.

4 Program Pushbutton

Press button (LED lights) and turn Adjust knob to select active program.

The letter C is displayed with the program number if the program has been changed from the factory settings using the optional PDA with PipePro Program Management software (PipeProMgr).

☞ The program cannot be changed through the front panel while welding.

Press and hold button to see program name. Custom programs are named using optional PDA with PipePro Program Management software (PipeProMgr). Program name is

shown in upper and lower displays (items 13 and 15).

5 Setup Mode Indicators

The lit LED indicates which setup mode is active. Setup mode parameters are shown in Display Windows (see Items 13 and 15).

Process LED

When this LED is lit, turn the Adjust knob to select the desired weld process. Choices include MIG welding (displayed as MIG), RMD-Pro (displayed as RMD), stick welding (displayed as STIK), and lift TIG welding (displayed as LIFT TIG).

Wire Type LED

When this LED is lit, turn the Adjust knob to select the desired wire type, wire alloy, and size. Wire type and size choices vary according to the selected weld process. Choices may include steel (displayed as STL), stainless steel (SS), metal core (MCOR). See Table 5-1 for all wire abbreviations.

Gas Type LED

When this LED is lit, turn the Adjust knob to select the desired weld gas. Gas type choices vary according to the selected weld process.

See Table 5-1 for all gas abbreviations.

6 Setup Push Button LED

The LED lights to indicate one of the setup modes is active.

7 Setup Pushbutton

Press button to select Process, Wire Type, Wire Diameter, or Gas Type parameters.

☞ In order for selections to be retained in memory, the Setup pushbutton must be pressed up to six times before any other button is pressed. The displays will temporarily show "PROG LOAD" to indicate the data is being stored in memory.

8 Arc Control LED

The LED lights to indicate the Arc Control button is active. Light goes out when button is inactive.

9 Arc Control Pushbutton

This button allows fine tuning inductance for MIG programs, and Arc Control for RMD programs, and DIG for Stick programs. When the button is pressed, the upper display (item 15) shows INDU for inductance, ARC for Arc Control, and DIG for Dig Control to indicate which parameter is selected to change. The range of possible values is 0-99 for inductance and dig, and 0-50 for arc control (factory default value is 25). Turn the Adjust knob to change the parameter value. Press button to deactivate arc control mode (LED goes out).

5-3. Front Panel Controls - Continued (See Section 5-2)

10 Wire Feed/Gas/Contactor LEDs

The Contactor LED lights when the output contactor is energized, making the weld output terminals live.

11 Wire Speed And Amps LEDs

The lit LED indicates whether wire speed or amps are being displayed.

12 Wire Feed Speed/Amps Display Pushbutton

This button toggles display information in MIG and RMD-Pro processes. Also, it is used to enable and disable the contactor in panel mode for stick, and TIG.

13 Lower Display

Press Wire Feed Speed/Amps Display button to show weld amperage or wire feed speed in lower display (the applicable LED under the lower display lights to indicate which is shown). When welding, actual value is shown.

If amperage was selected for display, the unit will show actual welding amperage prior to and while welding unless the unit is in Display Command Values mode. Only wire speed command will be displayed while welding if the unit is set in Display Command Values mode, even if the Wire Feed

Speed/Amps Display button is pressed.

Displays show actual or command values as determined by configuration menu when using a PDA with PipePro Program Management software (PipeProMgr). Command values are displayed prior to welding and actual values are displayed while welding unless a PDA with PipePro Program Management software (PipeProMgr) was used to set the unit in the "Display Command Values" mode. In the Display Command Values mode, command values are displayed while welding.

If a PDA with PipePro Program Management software (PipeProMgr) is used to change wire feed units (IPM, MPM) or display welding information (command or actual), save the changes and then turn the power to the unit off and then on again for the changes to be carried out by the unit.

14 Volts And Arc Adjust LEDs

The lit LED indicates whether voltage or arc length is being displayed.

15 Upper Display

The upper display shows different information depending on the active function of the unit and the weld process being used. When the display shows voltage (for a MIG process), the Volts LED lights. When it shows arc adjust [for an RMD-Pro weld process], the Arc Adjust LED lights. However, during any weld process (MIG and RMD), the unit will display actual arc voltage unless a PDA with PipePro Program Management software (PipeProMgr) has set the unit in the "Display Command Values" mode.

16 Lock LED

The lock LED is illuminated when one or more programs have been locked using an optional PDA with PipePro Program Management software (PipeProMgr). This may indicate that some programs have been disabled. A disabled program will not show up for selection. Other programs may be locked against editing.

The lock LED will also illuminate if the selected program is a custom program (indicated by a C next to the program number), indicating that it cannot be changed from the front panel. To clear a custom program when lock is not enabled, the front panel can be reset (resetting all 8 programs, see Section 5-16) or a new program can be loaded from the PDA.

Refer to the PipePro Program Management Owner's Manual for additional information.

5-4. Front Panel Switches

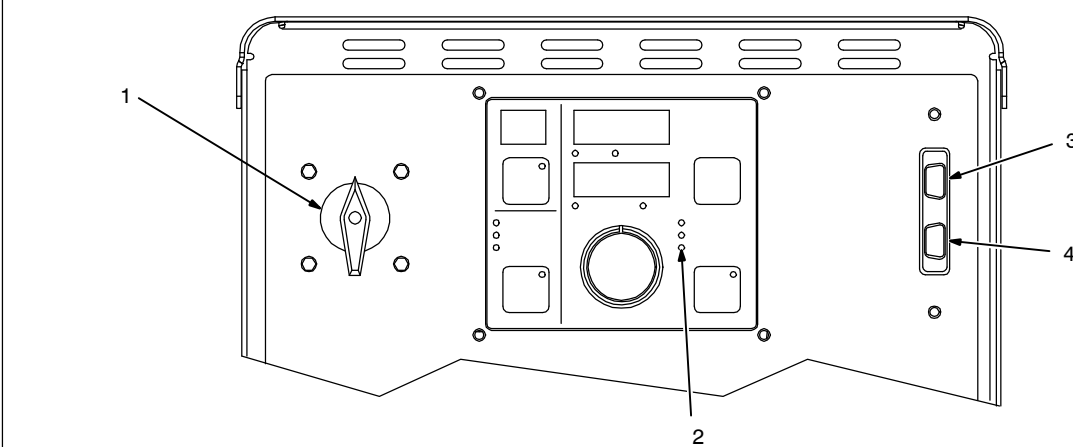
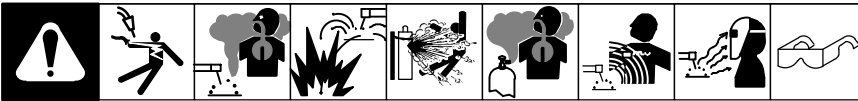

Ref. 803 246-B

1 Power Switch
Turns unit On or Off.

The power-up sequence may last up to 30 seconds before the unit is ready to weld. During power-up, the front panel will display messages indicating the status of the unit. The first message is:

PLS WAIT
PLS WAIT is an abbreviation for "network updating" and means the internal control network is powering up. The next message is **PRO 300**
PRO 300 indicates the final set-up sequence of the system.

2 Contactor LED
Contactor LED illuminates when weld output is energized.
3 PDA Port
4 PC Port

5-5. Typical Connection Diagram For MIG (GMAW) Equipment Using A Suitcase Feeder

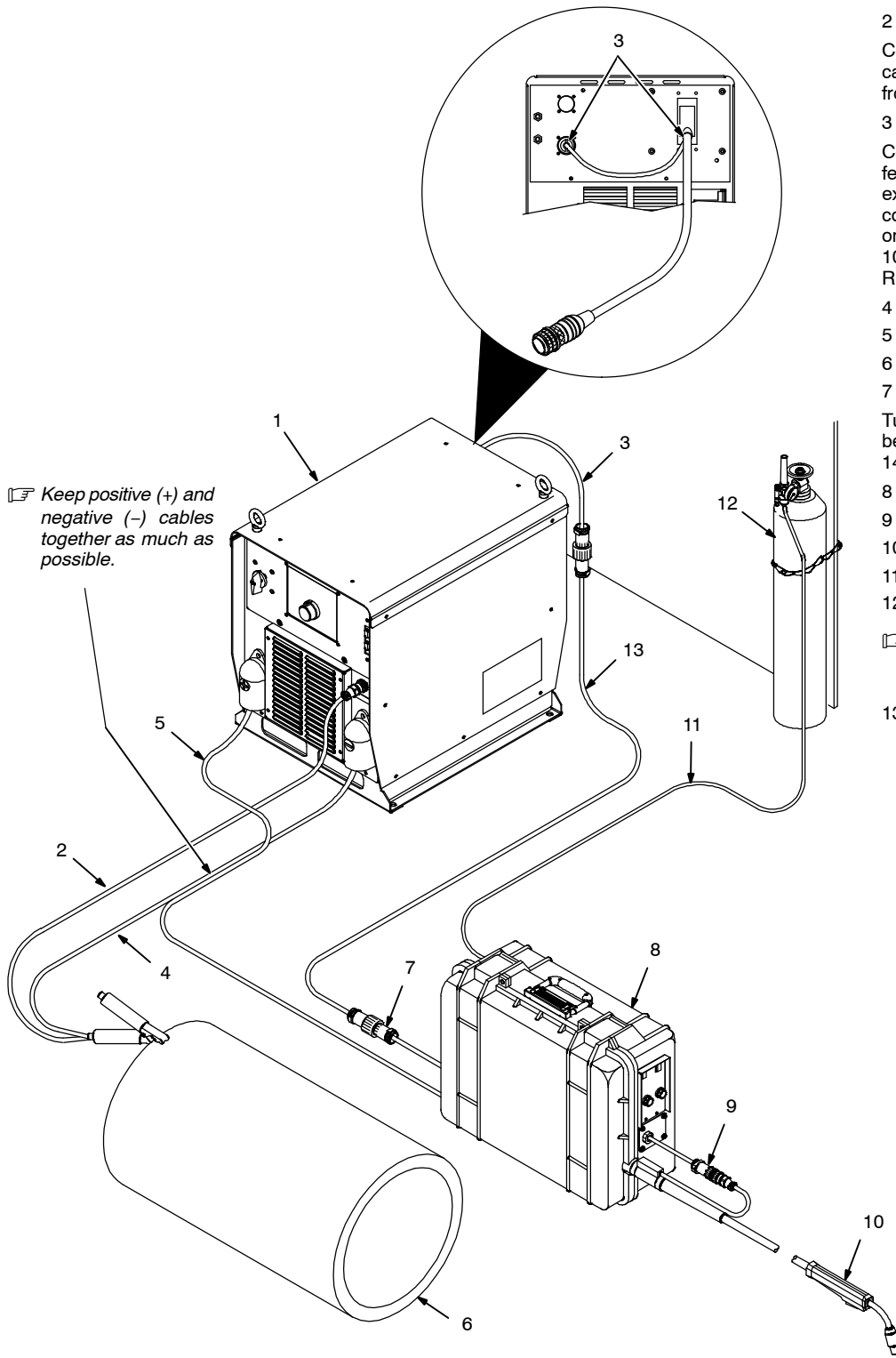
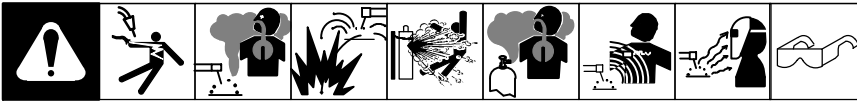

1 Welding Power Source

☞ Attach volt sense lead to work clamp and attach work clamp as close to arc as possible.

2 Negative Volt Sense Cable

Connect plug on end of volt sense cable to volt sense receptacle on front of welding power source.

3 Interconnect Cable

Connect 14-pin socket into wire feeder control cable or optional extension cable. Connect 72-pin connector to I/O receptacle RC72 on rear of power source. Connect 10-pin connector into receptacle RC8 on rear of power source.

4 Negative (-) Weld Cable

5 Positive (+) Weld Cable

6 Workpiece

7 Wire Feeder 14-Pin Plug

Turn off welding power source before connecting to wire feeder 14-pin plug.

8 Wire Feeder

9 Gun Trigger Receptacle

10 Gun

11 Gas Hose

12 Gas Cylinder

☞ Extension cable maximum length not to exceed 150 ft (46 m).

13 Extension Cable (Optional)

243 903-A

5-6. PipePro 300 Set Up For MIG (GMAW) Equipment

See Table 5-1 for selection choices.

1. Turn welding power source Power switch on (approximately 30 seconds for complete operation). Push Program button. Use the Adjust knob to choose a desired program number from the 1 through 8 selection.
 - ☞ *If the desired program has been previously loaded, only the program number needs to be selected. This process does not have to be followed every time a different program is selected.*
2. Push Setup button once. Use the Adjust knob to choose weld Process (MIG, Pro-Pulse, RMD-Pro, FCAW).
 - ☞ *FCAW has no wire settings, but does have a gas setting, go to Step 6.*
3. Push Setup button again. Use the Adjust knob to choose Wire Type (INCO, MCOR, CrMo, SS, or STL).
4. Push Setup button again. Use the Adjust knob to choose Alloy Type (filler metal classification).
5. Push Setup button again. Use the Adjust knob to choose Wire Diameter.
 - ☞ *MIG has no gas options, go to Step 7.*
6. Push Setup button again. Use the Adjust knob to choose Gas Mixture. For FCAW, choose "YES" or "NO".
7. Push Setup button again. The display will read PROG LOAD and welding power source is now ready for the welding operation.
 - ☞ *No changes are saved until PROG LOAD appears on the display after completing the settings. If the Setup button is pressed to review the settings and nothing is changed, PROG LOAD will not appear on the display for the program that was just loaded.*

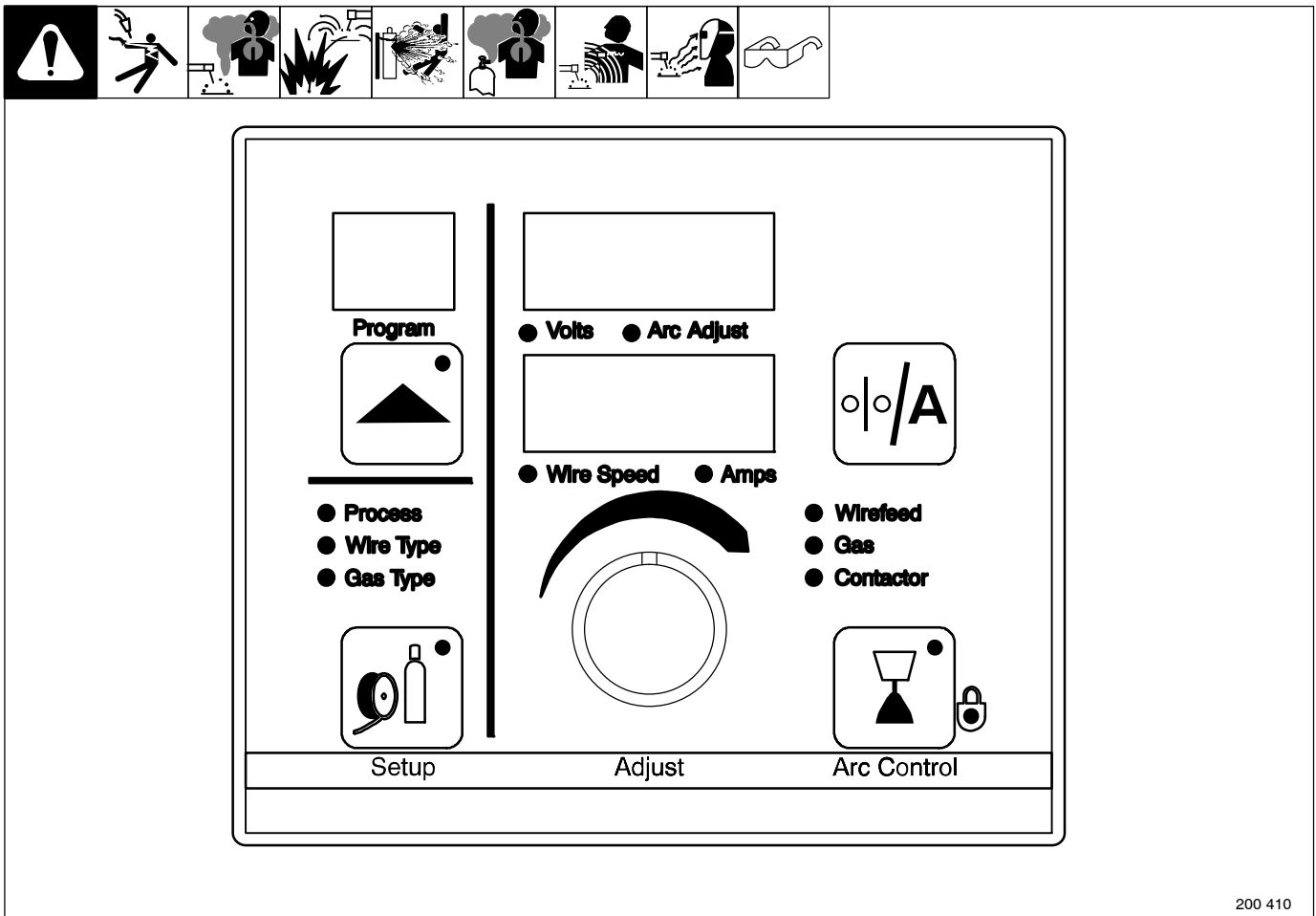

200 410

5-7. Typical Connection Diagram For TIG (GTAW) Equipment

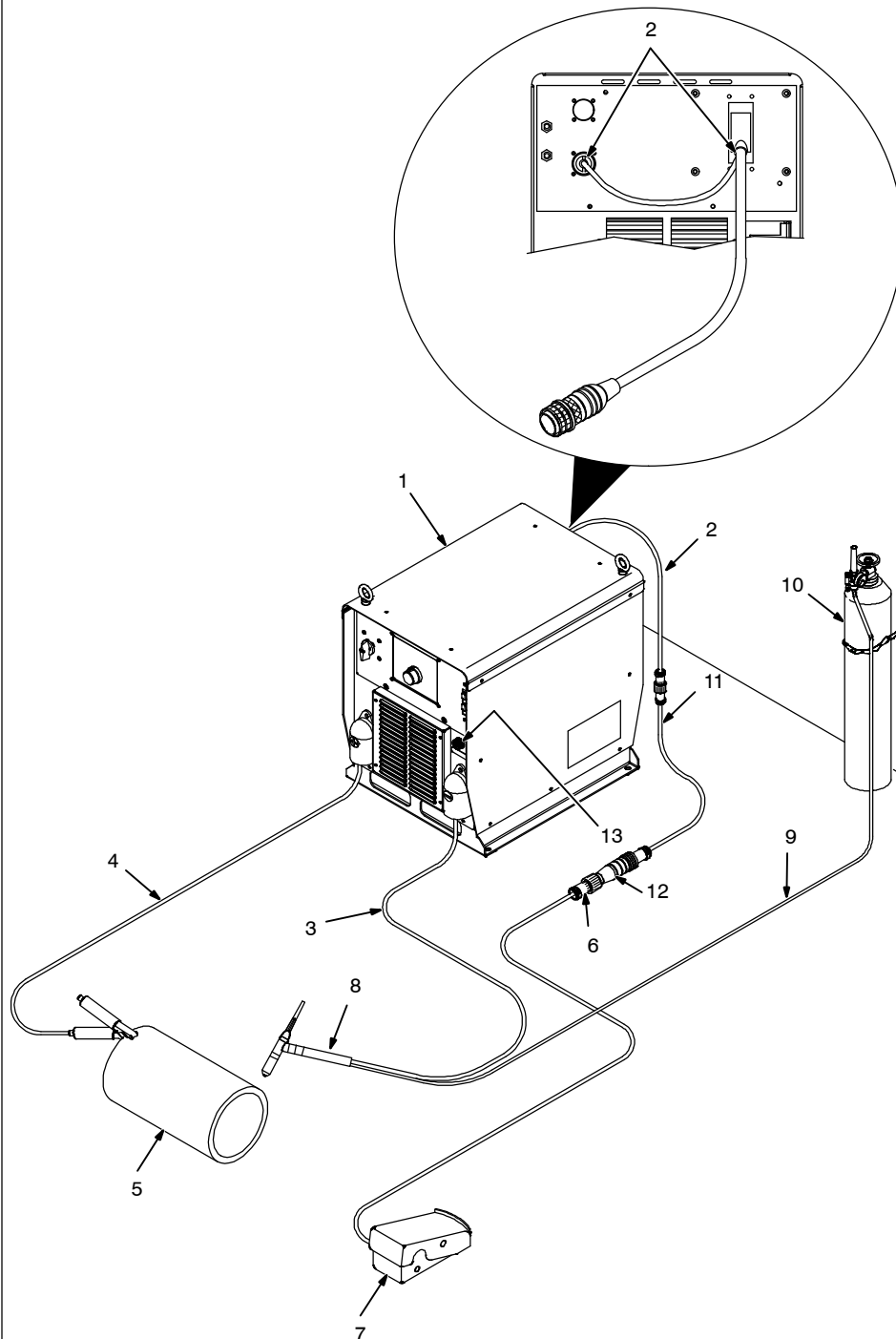
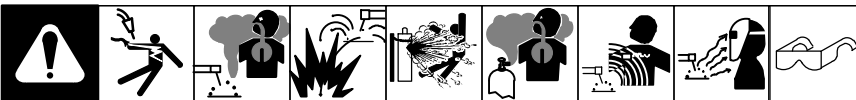

1 Welding Power Source

2 Interconnect Cable

Connect 14-pin socket into remote foot control cable or optional extension cable. Connect 72-pin connector to I/O receptacle RC72 on rear of power source. Connect 10-pin connector into receptacle RC8 on rear of power source.

3 Negative (-) Weld Cable

4 Positive (+) Weld Cable

5 Workpiece

6 14-Pin Plug On Remote Foot Control Cable

Turn off welding power source before connecting to foot control 14-pin plug.

7 Remote Foot Control

8 TIG Torch

9 Gas Hose

10 Gas Cylinder

 Extension cable maximum length not to exceed 150 ft (46 m).

11 Extension Cable (Optional)

12 Remote Adapter (300 248)

13 Volt Sense Receptacle (Cable Must Be Disconnected)

5-9. Typical Connection Diagram For Stick (SMAW) Equipment

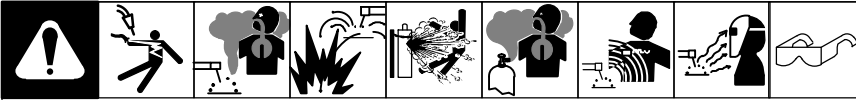

- 1 Welding Power Source
- 2 Interconnect Cable

Connect 14-pin socket into remote foot control cable or optional extension cable. Connect 72-pin connector to I/O receptacle RC72 on rear of power source. Connect 10-pin connector into receptacle RC8 on rear of power source.

 Attach volt sense lead to work clamp and attach work clamp as close to arc as possible.

- 3 Volt Sense Cable
- 4 Negative (-) Weld Cable
- 5 Positive (+) Weld Cable
- 6 Workpiece
- 7 14-Pin Plug On Remote Hand Control Cable

Turn off welding power source before connecting to hand control 14-pin plug.

- 8 Remote Hand Control
- 9 Electrode Holder

 Extension cable maximum length not to exceed 150 ft (46 m).

- 10 Extension Cable (Optional)
- 11 Remote Adapter (300 248)

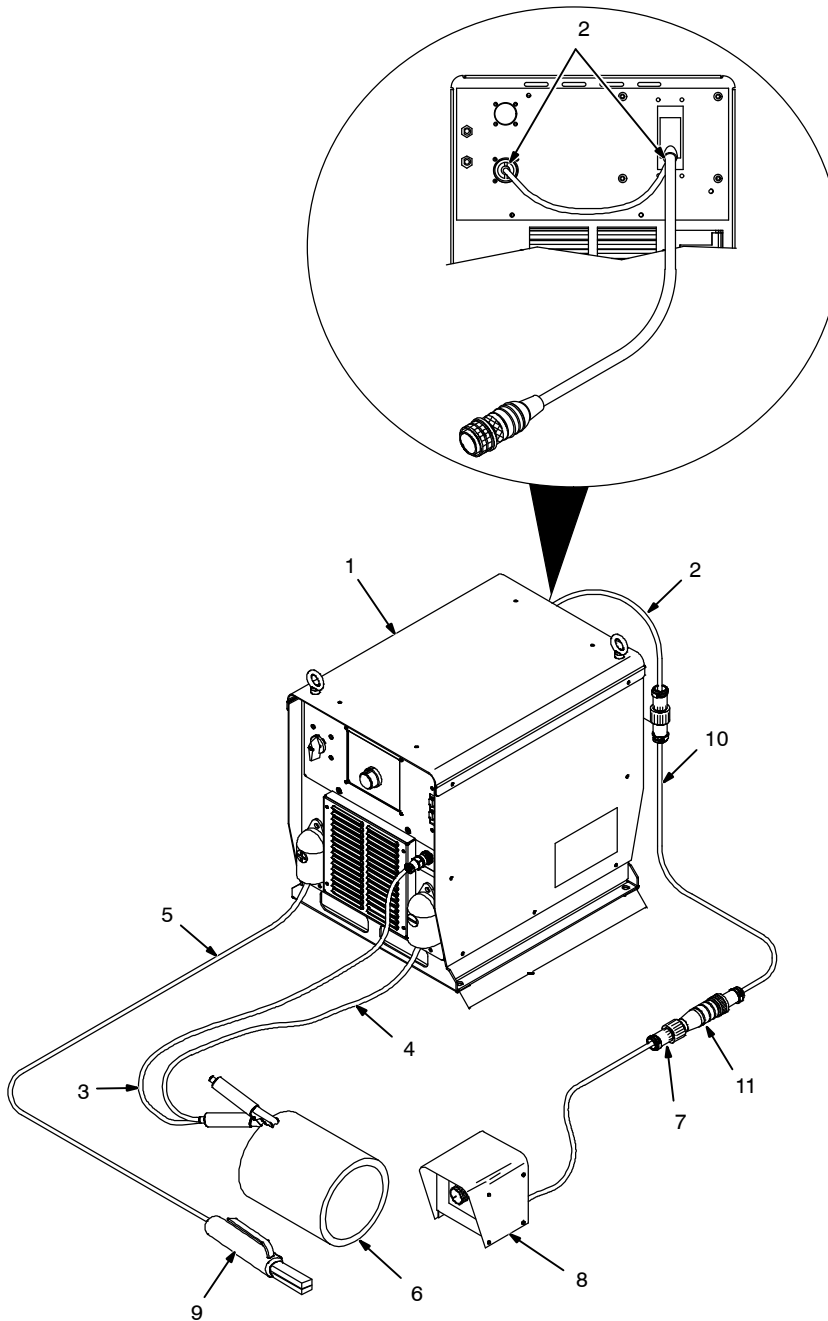

5-10. PipePro 300 Set Up For Stick (SMAW) Equipment

See Table 5-1 for selection choices.

1. Turn welding power source Power switch on (approximately 30 seconds for complete operation). Push Program button. Use the Adjust knob to choose a desired program number from the 1 through 8 selection.

☞ If the desired program has been previously loaded, only the program number needs to be selected. This process does not have to be followed every time a different program is selected.
2. Push Setup button once. Use the Adjust knob to choose Stick weld Process.
3. Push Setup button again. Use the Adjust knob to choose electrode type (EX10, EX18 OR ESS).
4. Push Setup button again. Use the Adjust knob to choose arc characteristic (ARC SOFT or ARC STIF).
5. Push Setup button again. Use the Adjust knob to choose type of Control (CTRL PANL or CTRL REMT).
 - a. If Panel control is selected, press the Wire Feed Speed/Amps display button for amperage output. Use the Adjust knob to set the desired amperage.
 - b. If Remote control is selected, connect a remote device using a remote cable adapter (300 248) to connect to an Interconnect Cable and then connect this cable to the PipePro 300. The remote device and the welding power source are now in a master/slave control configuration. The Adjust knob on the welding power source is used to control the maximum amperage that can be set by the remote device.
6. Push Setup button again. The display will read PROG LOAD and welding power source is now ready for the welding operation.

☞ No changes are saved until PROG LOAD appears on the display after completing the settings. If the Setup button is pressed to review the settings and nothing is changed, PROG LOAD will not appear on the display for the program that was just loaded.

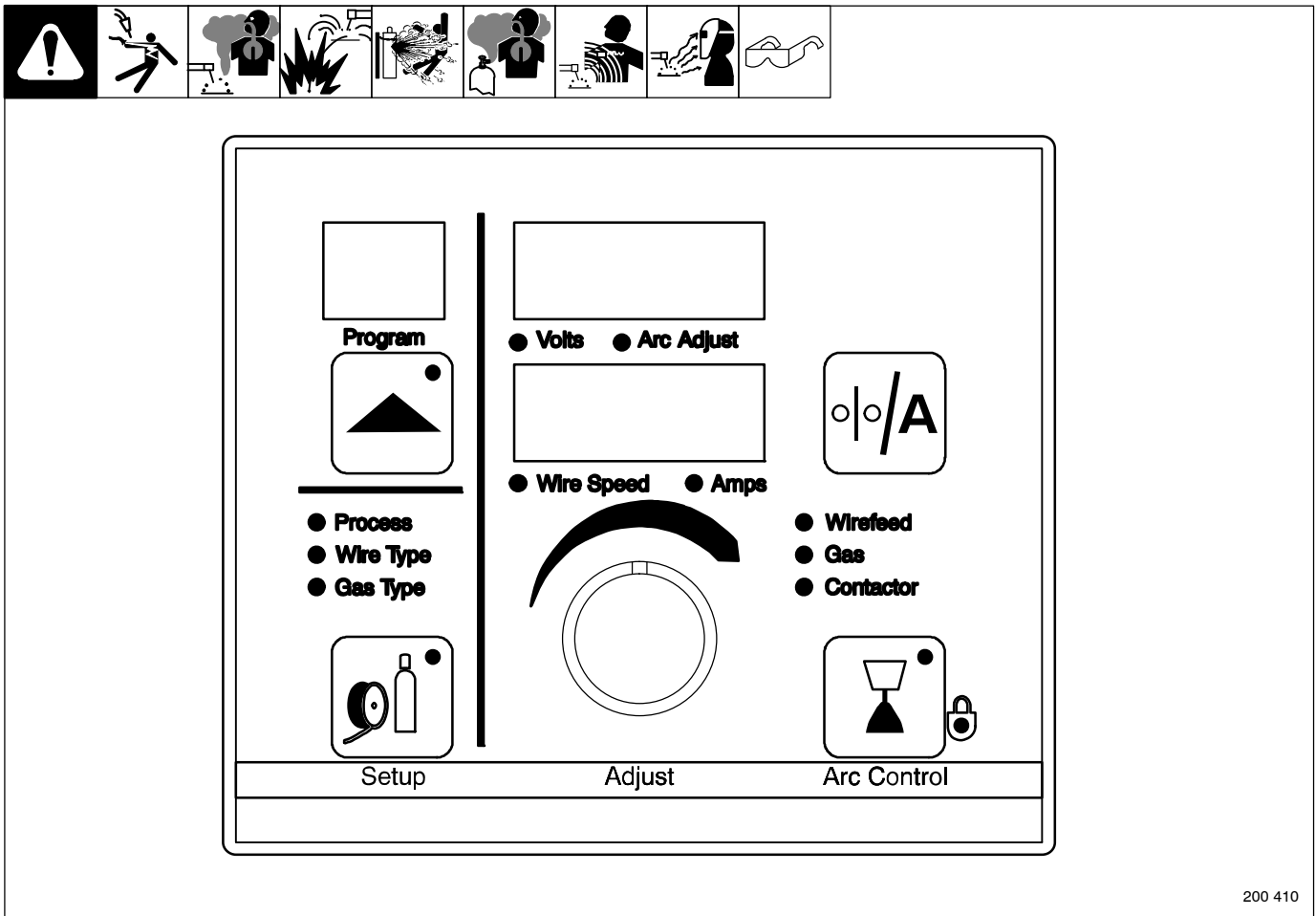

200 410

5-11. Isolating Two Processes Using Polarity Reversing/Isolation Control (042 871) Without HF Unit

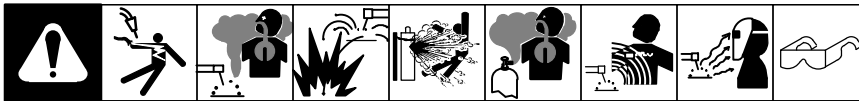

- 1 Electrode 1
- 2 Electrode 2
- 3 A Terminal
- 4 B Terminal
- 5 C Terminal

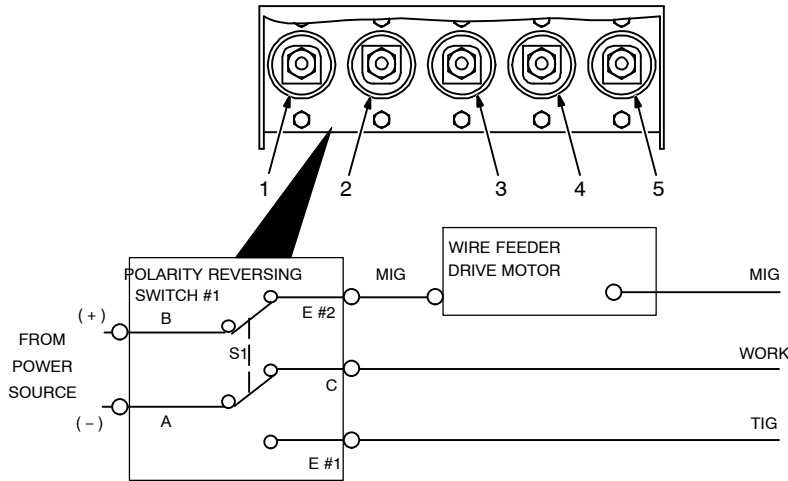

Tools Needed:



Ref. 099 082-C / Ref. 098 115-B

5-12. Isolating Three Processes Using Polarity Reversing/Isolation Control (042 871) Without HF Unit

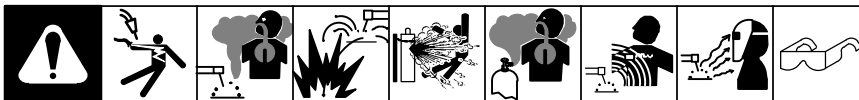

- 1 Electrode 1
- 2 Electrode 2
- 3 A Terminal
- 4 Bus Bar
- 5 B Terminal
- 6 C Terminal

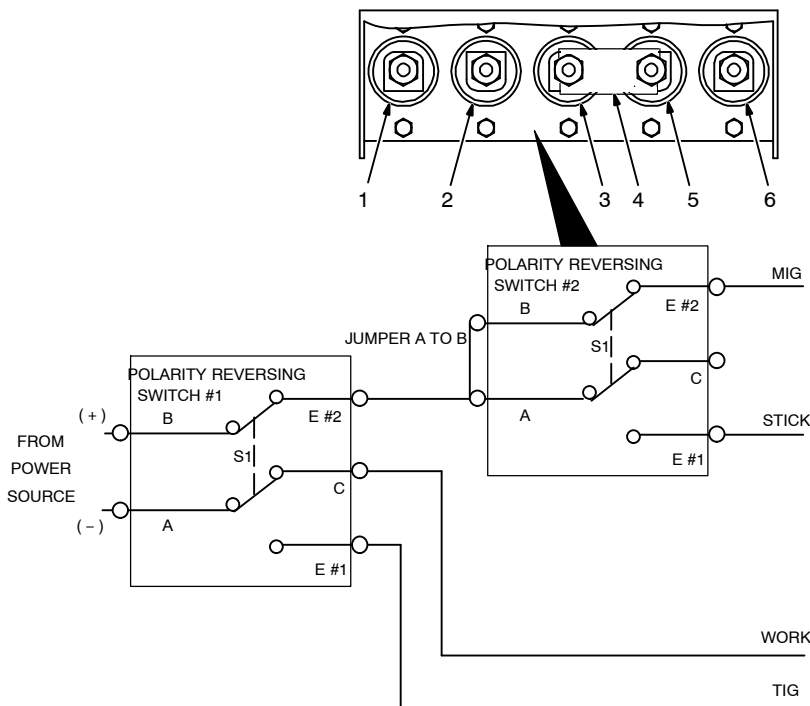

Tools Needed:



Ref. 099 082-C / Ref. 098 115-B

Table 5-1. Weld Programs

Process	Wire Type		Alloy Type	Diameter		Gas Mixture				
				inch	mm					
MIG	Metal Core	MCOR	76	0.045	1.2	N/A*	N/A*			
				0.052	1.3	N/A*	N/A*			
				0.062	1.6	N/A*	N/A*			
	Stainless Steel	SS	308, 309, 312, 316	0.035	0.9	N/A*	N/A*			
				0.045	1.2	N/A*	N/A*			
	Steel	STL	E70	0.035	0.9	N/A*	N/A*			
0.045				1.2	N/A*	N/A*				
Pro-pulse	Inconel	INCO	625	0.045	1.2	75% Argon, 25% Helium	HE25			
	Metal Core	MCOR	76	0.045	1.2	90% Argon, 10% CO ₂	C10			
						85% Argon, 15% CO ₂	C15			
				0.052	1.3	90% Argon, 10% CO ₂	C10			
						85% Argon, 15% CO ₂	C15			
	Stainless Steel	SS	308, 309, 312, 316	0.035	0.9	98% Argon, 2% CO ₂	C2			
						98% Argon, 2% Oxygen	OX2			
						81% Argon, 18% Helium, 1% CO ₂	TRIA			
						90% Helium, 7.5% Argon, 2.5% CO ₂	TRIH			
				0.045	1.2	98% Argon, 2% CO ₂	C2			
						98% Argon, 2% Oxygen	OX2			
						81% Argon, 18% Helium, 1% CO ₂	TRIA			
						90% Helium, 7.5% Argon, 2.5% CO ₂	TRIH			
				DPLX			0.040	1.0	69% Argon, 30% Helium, 1% CO ₂	TRI3
							0.045	1.2	69% Argon, 30% Helium, 1% CO ₂	TRI3
	Steel	STL	E70	0.035	0.9	90% Argon, 10% CO ₂	C10			
						85% Argon, 15% CO ₂	C15			
				0.040	1.0	90% Argon, 10% CO ₂	C10			
						85% Argon, 15% CO ₂	C15			
				0.045	1.2	90% Argon, 10% CO ₂	C10			
						85% Argon, 15% CO ₂	C15			
				0.052	1.3	90% Argon, 10% CO ₂	C10			
				0.062	1.6	90% Argon, 10% CO ₂	C10			
E80			0.040	1.0	85% Argon, 15% CO ₂	C15				
			0.045	1.2	85% Argon, 15% CO ₂	C15				
Pulse	Inconel	INCO	625	0.045	1.2	75% Argon, 25% Helium	HE25			

*PipePro 300 does not require a gas mixture selection for this process. See wire manufacturer for recommended gas mixture.

Table 5-1. Welding Programs (Continued)

Process	Wire Type		Alloy Type	Diameter		Gas Mixture	
				inch	mm		
RMD-Pro	Chrome Moly	CrMo	5%	0.045	1.2	75% Argon, 25% CO ₂	C25
	Metal Core	MCOR	76	0.045	1.2	90% Argon, 10% CO ₂	C10
				0.045	1.2	85% Argon, 15% CO ₂	C15
	Stainless Steel	SS	308, 316	0.035	0.9	98% Argon, 2% CO ₂	C2
						98% Argon, 2% Oxygen	OX2
						90% Helium, 7.5% Argon, 2.5% CO ₂	TRIH
				0.040	1.0	98% Argon, 2% CO ₂	C2
						98% Argon, 2% Oxygen	OX2
						90% Helium, 7.5% Argon, 2.5% CO ₂	TRIH
	0.045	1.2	98% Argon, 2% CO ₂	C2			
			98% Argon, 2% Oxygen	OX2			
			90% Helium, 7.5% Argon, 2.5% CO ₂	TRIH			
	Steel	STL	E70	0.035	0.9	90% Argon, 10% CO ₂	C10
						85% Argon, 15% CO ₂	C15
						75% Argon, 25% CO ₂	C25
						100% CO ₂	CO2
				0.040	1.0	90% Argon, 10% CO ₂	C10
						85% Argon, 15% CO ₂	C15
						75% Argon, 25% CO ₂	C25
						100% CO ₂	CO2
0.045			1.2	90% Argon, 10% CO ₂	C10		
				85% Argon, 15% CO ₂	C15		
	75% Argon, 25% CO ₂	C25					
	100% CO ₂	CO2					
E80			0.035	0.9	85% Argon, 15% CO ₂	C15	
					100% CO ₂	CO2	
FCAW	N/A					Gas	
						"YES" or "NO"***	
Stick	Stainless Steel	ESS	Arc Soft	Ctrl Panl		Press Wire Feed Speed/Amps Display button to turn output on	
	Steel	EX10	Arc Stif	Ctrl Remt		Use a remote control (must have contactor and amperage control) (remote adapter 300248 required)	
		EX18					
Carbon Arc Gouging	N/A						
Lift TIG	Ctrl Panl		Press Wire Feed Speed/Amps Display button to turn output on				
	Ctrl Remt		Use a remote control (must have contactor and amperage control) (remote adapter 300248 required)				
*PipePro 300 does not require a gas mixture selection for this process. See wire manufacturer for recommended gas mixture.							
**Wire diameter for self-shielded flux cored wire must not exceed 0.062 in. (1.6 mm).							

5-13. Basic Parameters For PipePro 300

Steel					
Process	Wire Size in (mm)	Wire Feed Speed IPM (mpm)	Arc Adjust/Trim	Arc Control	Shielding Gas
RMD Steel	.035 (0.9)	100-300 w/200 Nominal (2.5-7.7 w/5.1 Nominal)	47-53 w/50 Nominal	25	90/10
	.035 (0.9)	100-300 w/200 Nominal (2.5-7.7 w/5.1 Nominal)	47-53 w/50 Nominal	25	85/15
	.035 (0.9)	100-300 w/200 Nominal (2.5-7.7 w/5.1 Nominal)	47-53 w/50 Nominal	25	75/25
	.035 (0.9)	100-300 w/200 Nominal (2.5-7.7 w/5.1 Nominal)	47-53 w/50 Nominal	25	CO ₂
	.040 (1.0)	100-275 w/175 Nominal (2.5-7.0 w/4.4 Nominal)	50-55 w/53 Nominal	25	90/10
	.040 (1.0)	100-275 w/175 Nominal (2.5-7.0 w/4.4 Nominal)	47-53 w/50 Nominal	25	85/15
	.040 (1.0)	100-275 w/175 Nominal (2.5-7.0 w/4.4 Nominal)	50-55 w/53 Nominal	25	75/25
	.040 (1.0)	100-275 w/175 Nominal (2.5-7.0 w/4.4 Nominal)	50-55 w/53 Nominal	25	CO ₂
	.045 (1.1)	100-200 w/150 Nominal (2.5-5.1 w/3.8 Nominal)	47-53 w/50 Nominal	25	90/10
	.045 (1.1)	100-200 w/150 Nominal (2.5-5.1 w/3.8 Nominal)	47-53 w/50 Nominal	25	85/15
	.045 (1.1)	100-200 w/150 Nominal (2.5-5.1 w/3.8 Nominal)	47-53 w/50 Nominal	25	75/25
	.045 (1.1)	100-200 w/150 Nominal (2.5-5.1 w/3.8 Nominal)	47-53 w/50 Nominal	25	CO ₂
ProPulse Steel Using A Positioner (Rolling The Pipe)	.035 (0.9)	225-500 w/250 Nominal (5.7-12.7 w/6.4 Nominal)	52-57 w/56 Nominal	25	90/10
	.035 (0.9)	225-500 w/250 Nominal (5.7-12.7 w/6.4 Nominal)	52-57 w/56 Nominal	30-35	85/15
	.040 (1.0)	150-450 w/250 Nominal (3.8-11.4 w/6.4 Nominal)	52-56 w/56 Nominal	25	90/10
	.040 (1.0)	150-450 w/250 Nominal (3.8-11.4 w/6.4 Nominal)	52-56 w/56 Nominal	25	85/15
	.045 (1.1)	150-350 w/250 Nominal (3.8-8.9 w/6.4 Nominal)	52-57 w/56 Nominal	25	90/10
	.045 (1.1)	150-350 w/250 Nominal (3.8-8.9 w/6.4 Nominal)	52-57 w/56 Nominal	25	85/15
ProPulse Steel Welding In Position	.035 (0.9)	120-300 w/200 Nominal (3.0-7.6 w/5.1 Nominal)	52-57 w/54 Nominal	25	90/10
	.035 (0.9)	120-300 w/200 Nominal (3.0-7.6 w/5.1 Nominal)	52-57 w/54 Nominal	30-35	85/15
	.040 (1.0)	120-250 w/175 Nominal (3.0-6.4 w/4.4 Nominal)	52-56 w/54 Nominal	25	90/10
	.040 (1.0)	120-250 w/175 Nominal (3.0-6.4 w/4.4 Nominal)	52-56 w/54 Nominal	25	85/15
	.045 (1.1)	100-200 w/175 Nominal (2.5-5.1 w/4.4 Nominal)	50-55 w/53 Nominal	25	90/10
	.045 (1.1)	100-200 w/175 Nominal (2.5-5.1 w/4.4 Nominal)	50-55 w/53 Nominal	25	85/15

Stainless Steel					
Process	Wire Size in (mm)	Wire Feed Speed IPM (mpm)	Arc Adjust/Trim	Arc Control	Shielding Gas
RMD Stainless Steel	.035 (0.9)	120-290 w/200 Nominal (3.0-7.4 w/5.1 Nominal)	47-51 w/50 Nominal	25	Tri-H
	.040 (1.0)	120-275 w/200 Nominal (3.0-7.4 w/5.1 Nominal)	48-52 w/50 Nominal	30	Tri-H
	.040 (1.0)	120-275 w/200 Nominal (3.0-7.4 w/5.1 Nominal)	48-52 w/50 Nominal	25	98/2 CO ₂
	.040 (1.0)	120-275 w/200 Nominal (3.0-7.4 w/5.1 Nominal)	48-52 w/50 Nominal	25	98/2 Ox
	.045 (1.1)	120-160 w/150 Nominal (3.0-4.1 w/3.8 Nominal)	48-52 w/50 Nominal	25	Tri-H
ProPulse Stainless Steel Using A Positioner (Rolling The Pipe)	.035 (0.9)	225-500 w/175 Nominal (5.7-12.7 w/4.4 Nominal)	53-57 w/55 Nominal	25	Tri-H
	.035 (0.9)	225-500 w/175 Nominal (5.7-12.7 w/4.4 Nominal)	52-57 w/56 Nominal	16	Tri-A
	.035 (0.9)	225-500 w/175 Nominal (5.7-12.7 w/4.4 Nominal)	48-54 w/53 Nominal	18	98/2 CO ₂
	.035 (0.9)	225-500 w/175 Nominal (5.7-12.7 w/4.4 Nominal)	48-52 w/51 Nominal	18	98/2 Ox
	.045 (1.1)	150-350 w/200 Nominal (3.8-8.9 w/5.1 Nominal)	52-55 w/55 Nominal	25	Tri-H
	.045 (1.1)	150-250 w/200 Nominal (3.8-6.4 w/5.1 Nominal)	53-57 w/55 Nominal	16	98/2 CO ₂
	.045 (1.1)	150-250 w/200 Nominal (3.8-6.4 w/5.1 Nominal)	53-57 w/55 Nominal	25	98/2 Ox
ProPulse Stainless Steel Welding In Position	.035 (0.9)	120-300 w/175 Nominal (3.0-7.6 w/4.4 Nominal)	53-57 w/55 Nominal	25	Tri-H
	.035 (0.9)	120-300 w/175 Nominal (3.0-7.6 w/4.4 Nominal)	52-56 w/54 Nominal	16	Tri-A
	.035 (0.9)	120-300 w/175 Nominal (3.0-7.6 w/4.4 Nominal)	48-52 w/50 Nominal	18	98/2 CO ₂
	.035 (0.9)	120-300 w/175 Nominal (3.0-7.6 w/4.4 Nominal)	46-50 w/48 Nominal	18	98/2 Ox
	.045 (1.1)	100-200 w/140 Nominal (2.5-5.1 w/3.6 Nominal)	53-57 w/55 Nominal	25	Tri-H
	.045 (1.1)	100-200 w/140 Nominal (2.5-5.1 w/3.6 Nominal)	50-55 w/53 Nominal	16	98/2 CO ₂
	.045 (1.1)	100-200 w/140 Nominal (2.5-5.1 w/3.6 Nominal)	50-55 w/53 Nominal	25	98/2 Ox
	.045 Inconel 625	100-200 w/150 Nominal (2.5-5.1 w/3.8 Nominal)	50-55 w/53 Nominal	25-30	Argon

Flux Core					
Process	Wire Size in (mm)	Rolling Pipe/In Position Wire Feed Speed IPM (mpm)	Voltage	— —	Shielding Gas
Flux Core/GMAW	.045 (1.1)	175-300 w/200 Nominal (4.4-7.6 w/5.1 Nominal)*	23-27 w/25 Nominal	— —	75/25*
<p> Arc Control is arc width and Arc Adjust/Trim is arc length. Wire feed speed and voltage are synergic for the RMD and ProPulse processes. Therefore, when adjusting wire feed speed, the voltage is automatically adjusted so it is not necessary to adjust Arc Adjust/Trim. These are only starting parameters, the operator must make final adjustments depending on material and conditions.</p>					
<p>*See wire manufacturer for recommended wire feed speed and gas mixture.</p>					

5-14. Welding Stainless Steel With And Without Backing Gas Using PipePro 300

When welding stainless steel with or without backing gas, the following guidelines are recommended:

1. Only use stainless steel wire with a high silicon content as it helps the flow of the weld puddle and the silicon acts as a de-oxidizer.
2. It is important to have proper joint preparation and fit up. Use a bevel at the pipe joint of 35-37.5 degrees (70-75 degrees inclusive) with a land of a knife edge to 1/16 in. (1.6 mm) and a minimum gap of 1/8 in. (3.2 mm).
3. Be sure that any mill scale is removed from inside the pipe joint before welding the root weld. This can be done by grinding the inside of the joint area.
4. Use Tri-H (90% helium/7.5% Argon/2.5% CO₂ shielding gas). A 98/2 Argon/ is available, but the Tri-H mixture is the optimal choice for the application.
5. Always use a down hill technique when welding with the RMD process for the root pass weld.
6. It is very important to feather tack welds to ensure these are consumed when completing the root pass weld.
7. Always use a tapered nozzle when welding out the root especially with no backing gas to assist in providing adequate shielding gas coverage.

Following these guidelines should result in successful welding of stainless steel using the PipePro 300. Contact the nearest factory-authorized Distributor with any questions about this application.

5-15. Checking Program Revision

To enter the program revision mode, turn on welding power source, and press and hold the Setup push button in until PCM ###X appears on the display (message appears in approximately 15 seconds). Rotate Adjust knob to check the program revision level of each module as follows:

PCM (Process Control Module)
###X

UIM (User Interface Module)
###X

WFCM (Wire Feed Control Module)
###X

AIM (Automation Interface Module)
###X

To continue welding power source start up process after viewing program revision levels, press the Arc Control push button.

5-16. Reset Mode

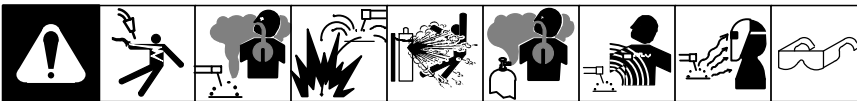

Reset mode is not active when Program Lock is enabled.

The reset mode allows the operator to reload factory program settings for all eight active programs in the unit.

System configuration data will be lost during the Reset operation.

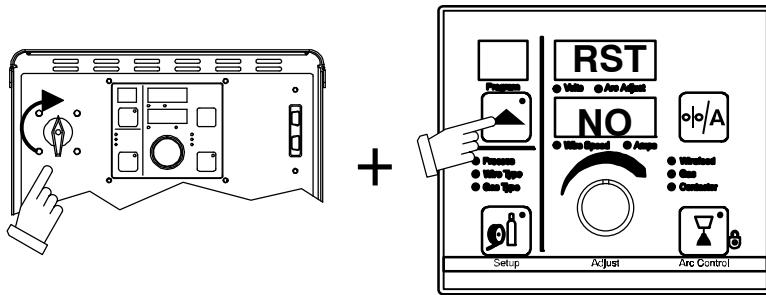

Enter reset mode by turning power On and pressing the Program Push Button until the RST NO message is displayed. RST NO message will not display until after the power-up sequence is completed (approximately 20 seconds).

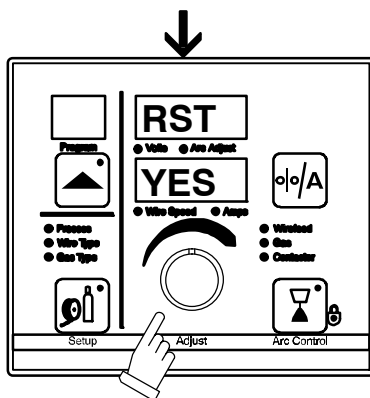

Rotate Adjust knob to change NO to YES.

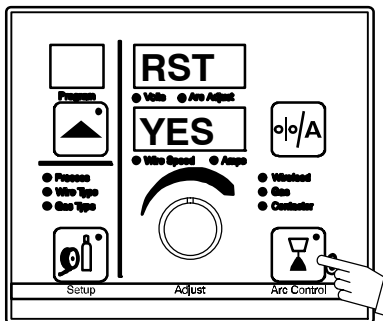

Press the Arc Control button to confirm the reset.

The reset message is displayed for 2 seconds while factory program settings are being reloaded.

During the reset mode the following factory default programs are loaded into the unit:

Program 1	RMD-Pro .045 Mild Steel E70 75% Argon, 25% CO ₂
Program 2	RMD-Pro .035 Metal Core E70 75% Argon, 25% CO ₂
Program 3	RMD-Pro .045 Metal Core 71 85% Argon, 15% CO ₂
Program 4	RMD-Pro .045 Metal Core 71 90% Argon, 10% CO ₂
Program 5	GMAW .035 Mild Steel E70 75% Argon, 25% CO ₂
Program 6	SMAW EXX10
Program 7	SMAW EXX18
Program 8	Lift TIG

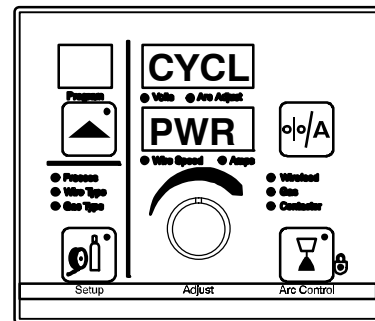

Cycl Pwr message appears on the display when programs complete loading.

Turn power off, wait 10 seconds, and turn power back on again to complete the reset operation.

After Reset is complete, be sure to load appropriate programs that contain the correct wire size, process, and shielding gas for the welding operation

SECTION 6 – MAINTENANCE

6-1. Routine Maintenance

				Disconnect power before maintaining.		<i>Maintain more often during severe conditions.</i>	
		✓ = Check ◇ = Change ● = Clean * To be done by Factory Authorized Service Agent		☆ = Replace		Reference	
Every 3 Months	☆ Unreadable Labels	● Weld Terminals	☆ Damaged Gas Hose	✓ ☆ Weld Cables			
	✓ ☆ Cords	✓ ☆ Gun Cables					
Every 6 Months	● Drive Rolls	● Inside Unit					

6-2. Blowing Out Inside Of Unit

		<p>Do not remove case when blowing out inside of unit.</p> <p>To blow out unit, direct airflow through front and back louvers as shown.</p>
243 893-A		

SECTION 7 – SAFETY PRECAUTIONS FOR SERVICING

! Protect yourself and others from injury — read, follow, and save these important safety precautions and operating instructions.

7-1. Symbol Usage

OM-246 466E - 2012-06, safety_stm 2011-10



DANGER! – Indicates a hazardous situation which, if not avoided, will result in death or serious injury. The possible hazards are shown in the adjoining symbols or explained in the text.



Indicates a hazardous situation which, if not avoided, could result in death or serious injury. The possible hazards are shown in the adjoining symbols or explained in the text.

NOTE – Indicates statements not related to personal injury.

Indicates special instructions.



This group of symbols means Warning! Watch Out! **ELECTRIC SHOCK, MOVING PARTS, and HOT PARTS** hazards. Consult symbols and related instructions below for necessary actions to avoid the hazards.

7-2. Servicing Hazards



The symbols shown below are used throughout this manual to call attention to and identify possible hazards. When you see the symbol, watch out, and follow the related instructions to avoid the hazard.



Only qualified persons should test, maintain, and repair this unit.



During servicing, keep everybody, especially children, away.



ELECTRIC SHOCK can kill.

- Do not touch live electrical parts.
- Turn Off welding power source and wire feeder and disconnect and lockout input power using line disconnect switch, circuit breakers, or by removing plug from receptacle, or stop engine before servicing unless the procedure specifically requires an energized unit.

- Insulate yourself from ground by standing or working on dry insulating mats big enough to prevent contact with the ground.
- Do not leave live unit unattended.
- If this procedure requires an energized unit, have only personnel familiar with and following standard safety practices do the job.
- When testing a live unit, use the one-hand method. Do not put both hands inside unit. Keep one hand free.
- Disconnect input power conductors from deenergized supply line BEFORE moving a welding power source.

SIGNIFICANT DC VOLTAGE exists in inverter welding power sources AFTER removal of input power.

- Turn Off inverter, disconnect input power, and discharge input capacitors according to instructions in Troubleshooting Section before touching any parts.

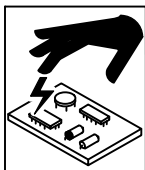

STATIC (ESD) can damage PC boards.

- Put on grounded wrist strap BEFORE handling boards or parts.
- Use proper static-proof bags and boxes to store, move, or ship PC boards.



FIRE OR EXPLOSION hazard.

- Do not place unit on, over, or near combustible surfaces.
- Do not service unit near flammables.

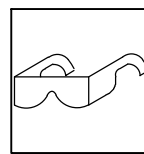

FLYING METAL or DIRT can injure eyes.

- Wear safety glasses with side shields or face shield during servicing.
- Be careful not to short metal tools, parts, or wires together during testing and servicing.



HOT PARTS can burn.

- Do not touch hot parts bare handed.
- Allow cooling period before working on equipment.
- To handle hot parts, use proper tools and/or wear heavy, insulated welding gloves and clothing to prevent burns.

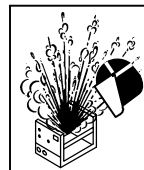

EXPLODING PARTS can injure.

- Failed parts can explode or cause other parts to explode when power is applied to inverters.
- Always wear a face shield and long sleeves when servicing inverters.

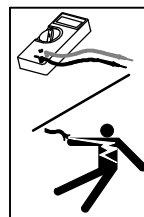

SHOCK HAZARD from testing.

- Turn Off welding power source and wire feeder or stop engine before making or changing meter lead connections.
- Use at least one meter lead that has a self-retaining spring clip such as an alligator clip.
- Read instructions for test equipment.



FALLING EQUIPMENT can injure.

- Use lifting eye to lift unit only, NOT running gear, gas cylinders, or any other accessories.
- Use equipment of adequate capacity to lift and support unit.
- If using lift forks to move unit, be sure forks are long enough to extend beyond opposite side of unit.
- Follow the guidelines in the Applications Manual for the Revised NIOSH Lifting Equation (Publication No. 94-110) when manually lifting heavy parts or equipment.



MOVING PARTS can injure.

- Keep away from moving parts such as fans.
- Keep away from pinch points such as drive rolls.
- Have only qualified persons remove doors, panels, covers, or guards for maintenance and troubleshooting as necessary.
- Keep hands, hair, loose clothing, and tools away from moving parts.
- Reinstall doors, panels, covers, or guards when maintenance is finished and before re-connecting input power.



ELECTRIC AND MAGNETIC FIELDS (EMF) can affect Implanted Medical Devices.

- Wearers of Pacemakers and other Implanted Medical Devices should keep away from servicing areas until consulting their doctor and the device manufacturer.

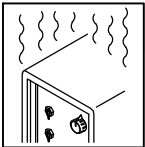

OVERUSE can cause OVERHEATING.

- Allow cooling period; follow rated duty cycle.
- Reduce current or reduce duty cycle before starting to weld again.
- Do not block or filter airflow to unit.

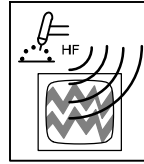

H.F. RADIATION can cause interference.

- High-frequency (H.F.) can interfere with radio navigation, safety services, computers, and communications equipment.
- Have only qualified persons familiar with electronic equipment install, test, and service H.F. producing units.
- The user is responsible for having a qualified electrician promptly correct any interference problem resulting from the installation.
- If notified by the FCC about interference, stop using the equipment at once.
- Have the installation regularly checked and maintained.
- Keep high-frequency source doors and panels tightly shut, keep spark gaps at correct setting, and use grounding and shielding to minimize the possibility of interference.

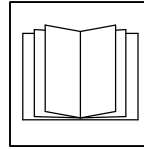

READ INSTRUCTIONS.

- Use Testing Booklet (Part No. 150 853) when servicing this unit.
- Consult the Owner's Manual for welding safety precautions.
- Use only genuine replacement parts from the manufacturer.
- Read and follow all labels and the Technical Manual carefully before installing, operating, or servicing unit. Read the safety information at the beginning of the manual and in each section.

7-3. California Proposition 65 Warnings

⚠ Welding or cutting equipment produces fumes or gases which contain chemicals known to the State of California to cause birth defects and, in some cases, cancer. (California Health & Safety Code Section 25249.5 et seq.)

⚠ This product contains chemicals, including lead, known to the state of California to cause cancer, birth defects, or other reproductive harm. *Wash hands after use.*

7-4. EMF Information

Electric current flowing through any conductor causes localized electric and magnetic fields (EMF). Welding current creates an EMF field around the welding circuit and welding equipment. EMF fields may interfere with some medical implants, e.g. pacemakers. Protective measures for persons wearing medical implants have to be taken. For example, restrict access for passers-by or conduct individual risk assessment for welders. All welders should use the following procedures in order to minimize exposure to EMF fields from the welding circuit:

1. Keep cables close together by twisting or taping them, or using a cable cover.
2. Do not place your body between welding cables. Arrange cables to one side and away from the operator.
3. Do not coil or drape cables around your body.

4. Keep head and trunk as far away from the equipment in the welding circuit as possible.
5. Connect work clamp to workpiece as close to the weld as possible.
6. Do not work next to, sit or lean on the welding power source.
7. Do not weld whilst carrying the welding power source or wire feeder.

About Implanted Medical Devices:

Implanted Medical Device wearers should consult their doctor and the device manufacturer before performing or going near arc welding, spot welding, gouging, plasma arc cutting, or induction heating operations. If cleared by your doctor, then following the above procedures is recommended.

SECTION 8 – TROUBLESHOOTING

8-1. Set Value Mode

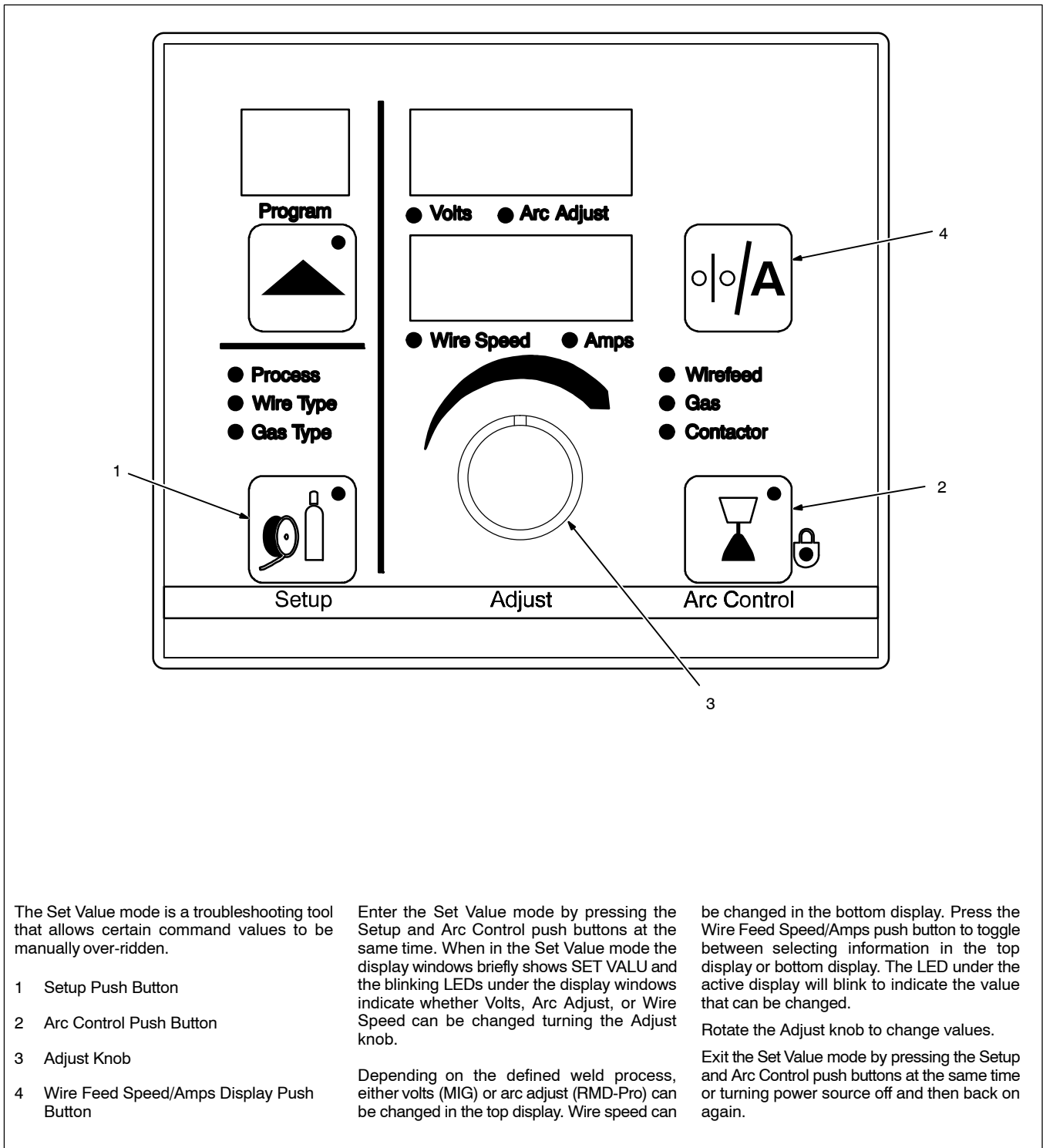

8-2. Troubleshooting Welding Power Source/Wire Feeder Issues

If the welding power source and wire feeder are NOT responding after everything is connected, follow the items listed below before contacting the nearest factory-authorized service agent:

Welding power source is plugged in and there is no power after turning on unit.

- If unit is directly connected to a line disconnect box or plugged into a receptacle from a line disconnect box, be sure that the line disconnect switch or main breaker is in the ON position.

Wire feeder has no power when turned on.

- Check if the 72-socket plug is connected to the receptacle on rear of welding power source, and check that the 14-pin plug from the wire feeder is connected to the matching receptacle on rear of welding power source.

Wire does not feed from wire feeder to end of gun.

- Check to see if wire diameter matches the groove size of the drive rolls.
- Check if tension on drive rolls is too loose or too tight.
- Check if gun liner is the correct size for the wire size.
- Check if contact tip is correct size for the wire size, and that end of contact tip is not plugged.
- Check if gun end is fully inserted into wire drive housing at feeder, and knob is tightened down to secure gun end.

Weld is not consistent from one welding application to another.

- Be sure that ground is connected to a clean, paint-free area of pipe; otherwise, grind an area if necessary to make a good ground connection.
- Keep ground as close as possible to joint being welded.
- Check if volt sensing lead is connected to the welding power source and that ground connection is secure. Check for any frayed wires at ground end of volt sensing lead that may prevent a good connection.
- Be sure that volt sense lead shielding is not touching center conductor.
- Be sure that wire feeder control cable and volt sensing lead are separated from weld cables.
- Be sure gun angle during welding is straight in to 15 degrees back at joint.
- Follow recommended settings in Operation section of manual to select a starting point for welding.
- Recommended joint preparation and fit-up is 1/32-1/16 in (0.8-1.6 mm) land and a 1/8 in (3.2 mm) root opening.

Porosity in weld bead.

Check shielding gas supply that there is enough gas and supply is turned on.

Check shielding gas flow rate at regulator.

Check that gas pressure to the wire feeder does not exceed 90 psi (621 kPa).

Check all shielding gas fitting and tighten if necessary.

Remove gun end from wire drive housing and check condition of O-rings. Replace any worn or missing O-rings.

Check power pin end of gun and tighten with a wrench.

Be sure that gun end is fully inserted into wire drive housing and knob is tightened down to secure gun end.

Check and clean shielding gas nozzle on gun.

Trouble feeding wire when welding. Check drive rolls and wire guides to make sure they match the wire style and size.

Check drive roll tension and readjust if necessary.

Be sure that gun end is fully inserted into wire drive housing and knob is tightened down to secure gun end.

Check if hub tension at wire spool is too tight or too loose and readjust if necessary.

Be sure that welding gun cable is as straight as possible from wire feeder to workpiece.

Check if contact tip is correct size for the wire size, and that end of contact tip is not plugged.

Check if gun liner is the correct size for the wire size and liner is not dirty or damaged. Clean or replace gun liner if necessary.

8-3. Diagnostics

The following error messages are shown on the upper and lower displays to indicate specific errors. Explanations are in the text below:

ERR

ARC

Indicates an arc error.

ERR

GND

Indicates a ground current error.

ERR

LINE

Indicates a line error.

ERR

STRT

Indicates an arc start error.

ERR

STUK

Indicates a wire stuck error.

ERR

TEMP

Indicates a temperature error.

PLS

WAIT

Indicates a UIM communication error.

ERR

SENS

Indicates no ocv.

E

STOP

Indicates an emergency stop error.

ERR

UNKN

Indicates an unknown error.

OVER

CRNT

Indicates an overcurrent error.

OVER

AVG

Indicates an over average current error.

UNIT

COMM

Indicates a CRC PCM bus error.

NET

WAIT

Indicates a network communication error.

ERR ARC

- **The arc error** indicates an arc outage occurred possibly from a wire feeder error or power source error. Check wire feeder and power source. Press any button on front panel to clear error.

ERR GND

- **The ground current error** occurs if weld current is detected in the earth ground connection. May be caused by a conductor making contact with unit chassis. Check and repair feeder weld connections. Press any button on front panel to clear error.

ERR LINE

- **The line error** indicates input power is outside of unit operating range. Check and correct input power. Cycle power to clear error.

ERR STRT

- **The start error** occurs if the user has the trigger held for more than 3 seconds without striking an arc and Start Err is enabled. This error also occurs if trigger jog runs for 30 seconds or more. The error may be cleared by releasing the trigger, and pressing any button on the front panel.

ERR STUK

- **The stuck error** occurs if the welding wire sticks to the workpiece at the end of a weld. May be caused by poor weld conditions. The error may be cleared by cutting wire from workpiece, and pressing any button on the front panel.

ERR TEMP

- **The temperature error** indicates welding power source has overheated and shutdown. The error may be cleared by allowing unit to cool down, and cycle power to clear error. If problem persists, check fan motors for proper operation. If unit is not overheated, check that input line voltages are within specifications. If input line voltages are okay, contact nearest factory authorized Service Agent.

PLS WAIT

- **The uim communication error** indicates user interface module PC7 lost data communications. Press any button on front panel to clear error. If condition persists, contact nearest factory authorized Service Agent.

ERR SENS

- **The sensing error** indicates no ocv when operating with electrode negative in Stick, or TIG. Remove volt sense lead and press any button on front panel to clear error.

E STOP

- **The emergency stop error** indicates no connection is made to the 72-pin connector on the rear of the unit. Connect "Y" cable to rear of welding power source.

ERR UNKN

- **The unknown error** indicates an error was sent from the process control module PC4 to the user interface module PC7, but the error condition is unknown. Make sure that welding power source is isolated from the welding fixture. Leave the unit powered up for five minutes and then turn on the contactor to clear the fault.

OVER CRNT

- **The over current error** indicates welding power source primary current of the inverter is too high. Turn welding power source off and disconnect unit for servicing. Attempting to reset the display to continue welding may further damage internal components. Contact nearest factory authorized service agent.

OVER AVG

- **The over average error** indicates that current is outside the average range for the set program parameters. Check and correct program parameters. Leave the unit powered up for five minutes and then turn on the contactor to clear the fault.

UNIT COMM

- **The unit communication error** indicates the data bus on the PCM board is not functioning properly. Press Jog/Purge button to clear error. Leave the unit powered up for five minutes and then turn on the contactor to clear the fault.

NET WAIT

- **The network wait error** indicates that the UIM board PC7 is no longer communicating with the PCM board PC4 by DeviceNet. Turn welding power source off and disconnect unit for servicing. Contact nearest factory authorized service agent.

8-4. Removing Cover and Measuring Input Capacitor Voltage



Tools Needed:

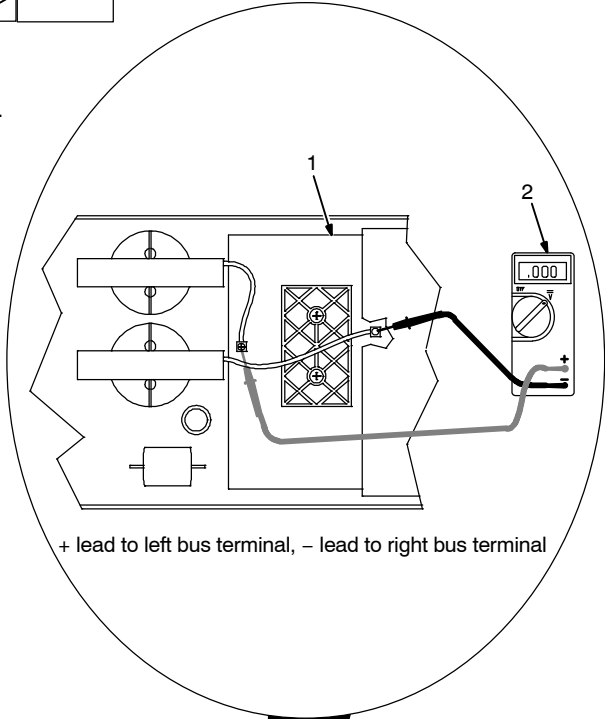
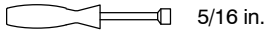

⚠ Turn Off welding power source, and disconnect input power.

⚠ Significant DC voltage can remain on capacitors after unit is Off. Always check the voltage as shown to be sure the input capacitors have discharged before working on unit.

Remove lifting eyes, top cover and side panels.

1 Power Interconnect Board
PC2

2 Voltmeter

Measure the dc voltage across the + bus terminal and - bus terminal on PC2 as shown until voltage drops to near 0 (zero) volts. Measure input capacitor voltage on both inverter assemblies before proceeding.

3 Typical Bleeder Resistor

An example of a typical bleeder resistor is shown on this page.

Proceed with job inside unit. Reinstall cover when finished.

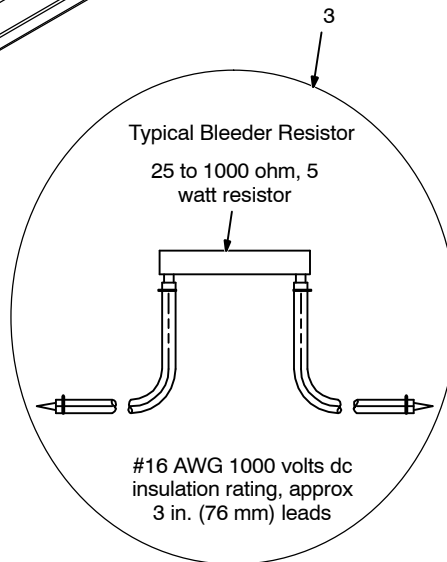
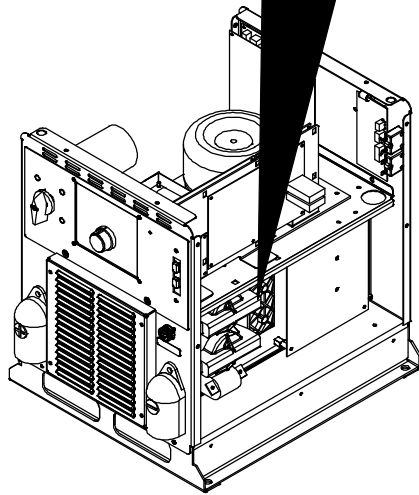

8-5. Process Control Module PC4 Diagnostic LEDs



1 Process Control Module PC4

Diagnostic LEDs are visible inside unit, located on PC4 mounted on the top tray.

Refer to Section 8-6 for information on diagnostic LEDs.

Reinstall cover after checking diagnostic LEDs.

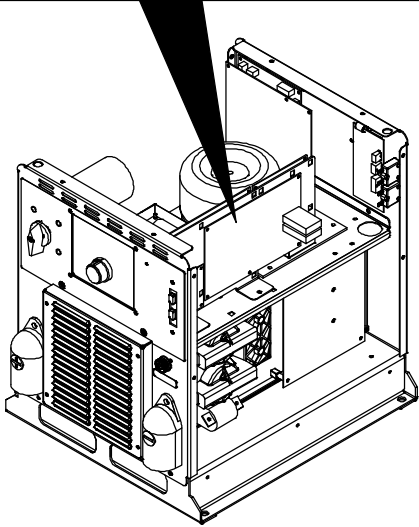
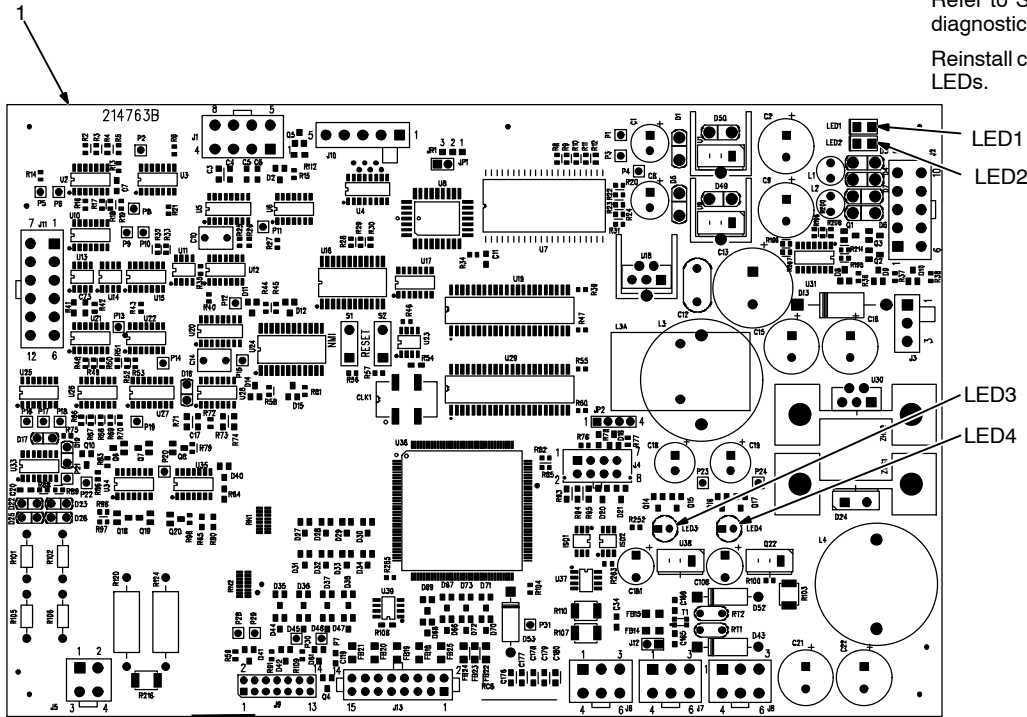





216 956-A / 243 896-A

8-6. Diagnostic LEDs On Process Control Module PC4

LED	Status	Diagnosis
1	On	Indicates -25 volts dc is present on process control module PC4
	Off	Indicates -25 volts dc is not present on process control module PC4
2	On	Indicates +25 volts dc is present on process control module PC4
	Off	Indicates +25 volts dc is not present on process control module PC4
3,4	On	See Network Status Table in Section 8-11
	Off	See Network Status Table in Section 8-11

8-7. User Interface Module PC7 Diagnostic LEDs

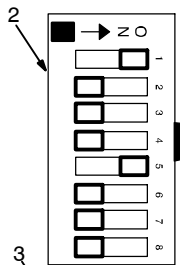

2

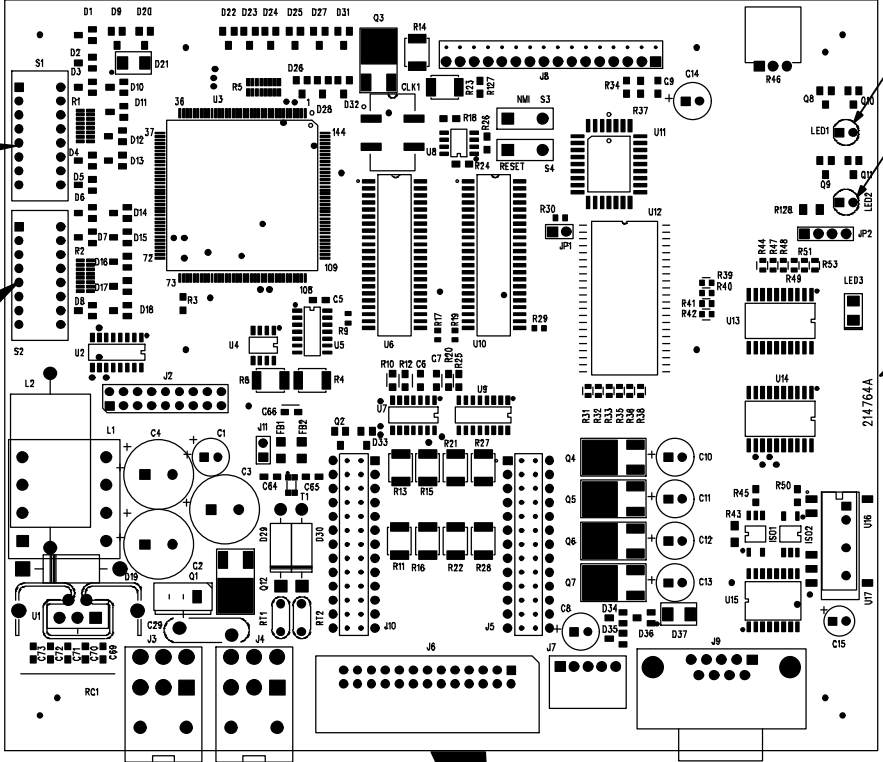

LED1

LED2

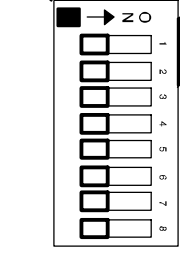

3

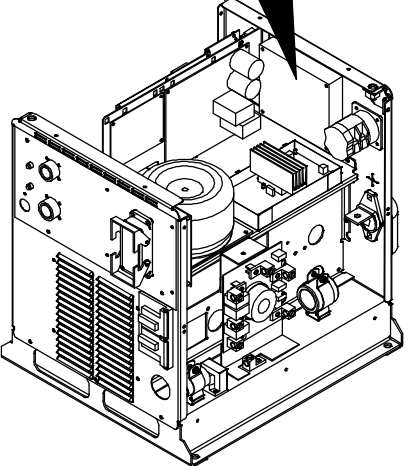

1 User Interface Module PC7
Diagnostic LEDs are visible inside unit, located on PC7 mounted behind the front panel.
Refer to Section 8-8 for information on diagnostic LEDs.

Reinstall cover after checking diagnostic LEDs.

2 Dip Switch S1

3 Dip Switch S2

Dip switches are used to identify each circuit board on the internal network. Dip switch settings are different for each circuit board. For proper operation, do not change dip settings from those shown.

218 559-A / 804 756-A

8-8. Diagnostic LEDs On User Interface Module PC7

LED	Status	Diagnosis
1, 2	On	See Network Status Table in Section 8-11
	Off	See Network Status Table in Section 8-11

8-9. Automation Interface Module PC9 Diagnostic LEDs

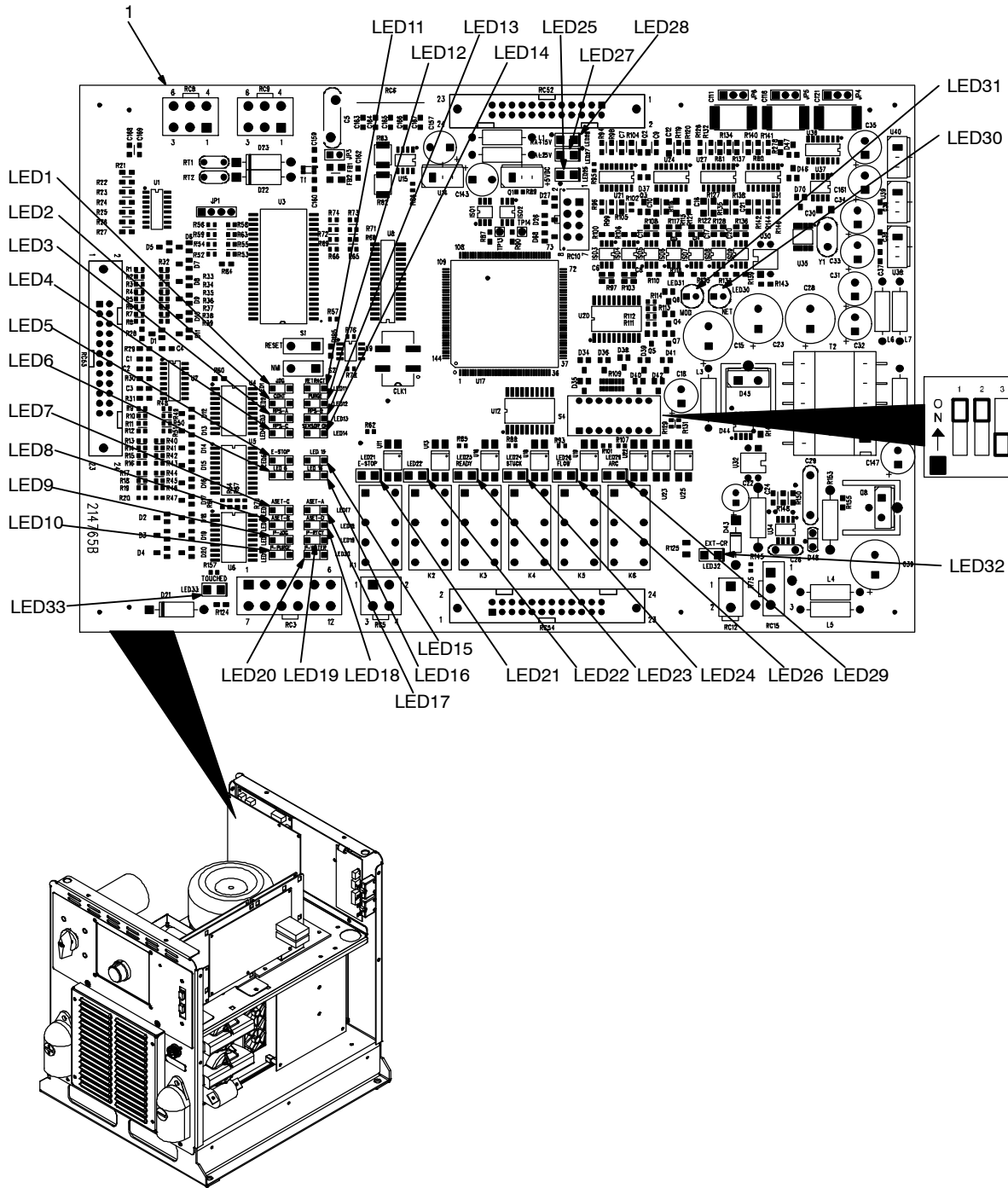

216 958-A / 243 896-A

1 Automation Interface Module PC9
Diagnostic LEDs are visible inside unit,
located on PC9 mounted on left side.
Refer to Section 8-10 for information on
diagnostic LEDs.

Reinstall cover after checking diagnostic
LEDs.

2 Dip Switch S4

Dip switches are used to identify each
circuit board on the internal network. Dip
switch settings are different for each circuit
board. For proper operation, do not change
dip settings from those shown.

8-10. Diagnostic LEDs On Automation Interface Module PC9

LED	Status	Diagnosis
1	On	Input signal On from robot for jog advance
	Off	Input signal Off from robot for no jog advance
2*	On	Input signal On from robot to energize contactor
	Off	Input signal Off from robot to not energize contactor
3	On	Input signal On remote program A selected
	Off	Input signal Off remote program A not selected
4	On	Input signal On remote program C selected
	Off	Input signal Off remote program C not selected
5	On	Input signal On from E-stop board PC12 for no emergency stop
	Off	Input signal Off from E-stop board PC12 acknowledges E-stop is On from robot
6	On	Spare 1 not assigned
	Off	Spare 1 not assigned
7	On	Input signal On Autoset-C selected
	Off	Input signal Off Autoset-C not selected
8	On	Input signal On Autoset-B selected
	Off	Input signal Off Autoset-B not selected
9	On	Input signal On Remote Jog on from peripheral plug
	Off	Input signal Off Remote Jog off from peripheral plug
10	On	Input signal On Remote Purge on from peripheral plug
	Off	Input signal Off Remote Purge off from peripheral plug
11	On	Input signal On from robot for jog retract
	Off	Input signal Off from robot for no jog retract
12	On	Input signal On from robot for purge
	Off	Input signal Off from robot for no purge
13	On	Input signal On remote program B selected
	Off	Input signal Off remote program B not selected
14	On	Input signal On Touch Sensor on from robot or peripheral plug
	Off	Input signal Off Touch Sensor off from robot or peripheral plug
15	On	Spare 0 not assigned
	Off	Spare 0 not assigned
16	On	Spare 2 not assigned
	Off	Spare 2 not assigned
17	On	Input signal On Autoset-A selected
	Off	Input signal Off Autoset-A not selected
18	On	Input signal On Autoset-D selected
	Off	Input signal Off Autoset-D not selected
19	On	Input signal On Remote Retract on from peripheral plug
	Off	Input signal Off Remote Retract off from peripheral plug
20	On	Input signal On Remote Water Flow on from peripheral plug
	Off	Input signal Off Remote Water Flow off from peripheral plug
21*	On	Input signal On from robot for no emergency stop
	Off	Input signal Off from robot for emergency stop
23	On	Input signal On from relay K3 for welding power source ready and no detected errors present
	Off	Input signal Off from relay K3 for welding power source not ready, detected errors are present, or unit is in operating mode preventing the weld ready signal from being enabled

8-11. Network And Module Status LEDs

A. Network Status LEDs

The following are network status LEDs:

LED1 on the UIM circuit board

LED4 on the WFM and PCM circuit boards

LED30 on the AIM circuit board.

Status	Diagnosis
Both LEDs Off	The circuit board is not on-line with the network or there is no power applied to the circuit board.
Both LEDs Green	The circuit board is operating normally and the on-line connection is made with the network.
Flashing Green	The circuit board is waiting for an on-line connection to be made with the network.
Red	The circuit board has encountered a communication link failure with the network. Check DeviceNet cable connections. Verify dip switch positions according to Sections 8-7 and 8-9. Replace circuit board if necessary.

B. Module Status LEDs

The following are module status LEDs:

LED2 on the UIM circuit board

LED3 on the WFM and PCM circuit boards

LED31 on the AIM circuit board.

Status	Diagnosis
Off	There is no power applied to the circuit board or the board software is not executing its functions.
Green	The circuit board is operating normally.
Flashing Red	The circuit board has encountered a recoverable fault. Wait or cycle power to clear fault.
Red	The circuit board has encountered an unrecoverable fault.

8-12. Troubleshooting

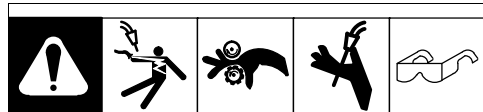

Trouble	Remedy
No weld output; completely inoperative	Place line disconnect in On position (see Section 4-14).
	Check and replace line fuse(s), if necessary, or reset circuit breaker (see Section 4-14).
	Check for proper input power connections (see Section 4-14).
No weld output; meter display on with no error displayed.	Check to see if the contactor indicator light is lit when contactor line is asserted on.
Erratic or improper weld output with no errors displayed.	Use proper size and type of weld cable (see Section 4-6).
	Check that proper program for wire size, process, and shielding gas is loaded.
	Clean and tighten all weld connections.
No 115 volts AC at the duplex receptacle.	Reset supplementary protector CB1.
Wire feeder has no power.	Check supplementary protector CB2 and reset if necessary.
	Check motor control cable connections.
Wire stubbing on low end using a constant current power source.	Increase output setting of the power source.
	Check voltage sense lead connection, clean and tighten if necessary.
Wire burns back to gun contact tip when using electrode negative (straight polarity) process.	Check to be sure that volt sense lead is connected to the work.

SECTION 9 - ELECTRICAL DIAGRAMS

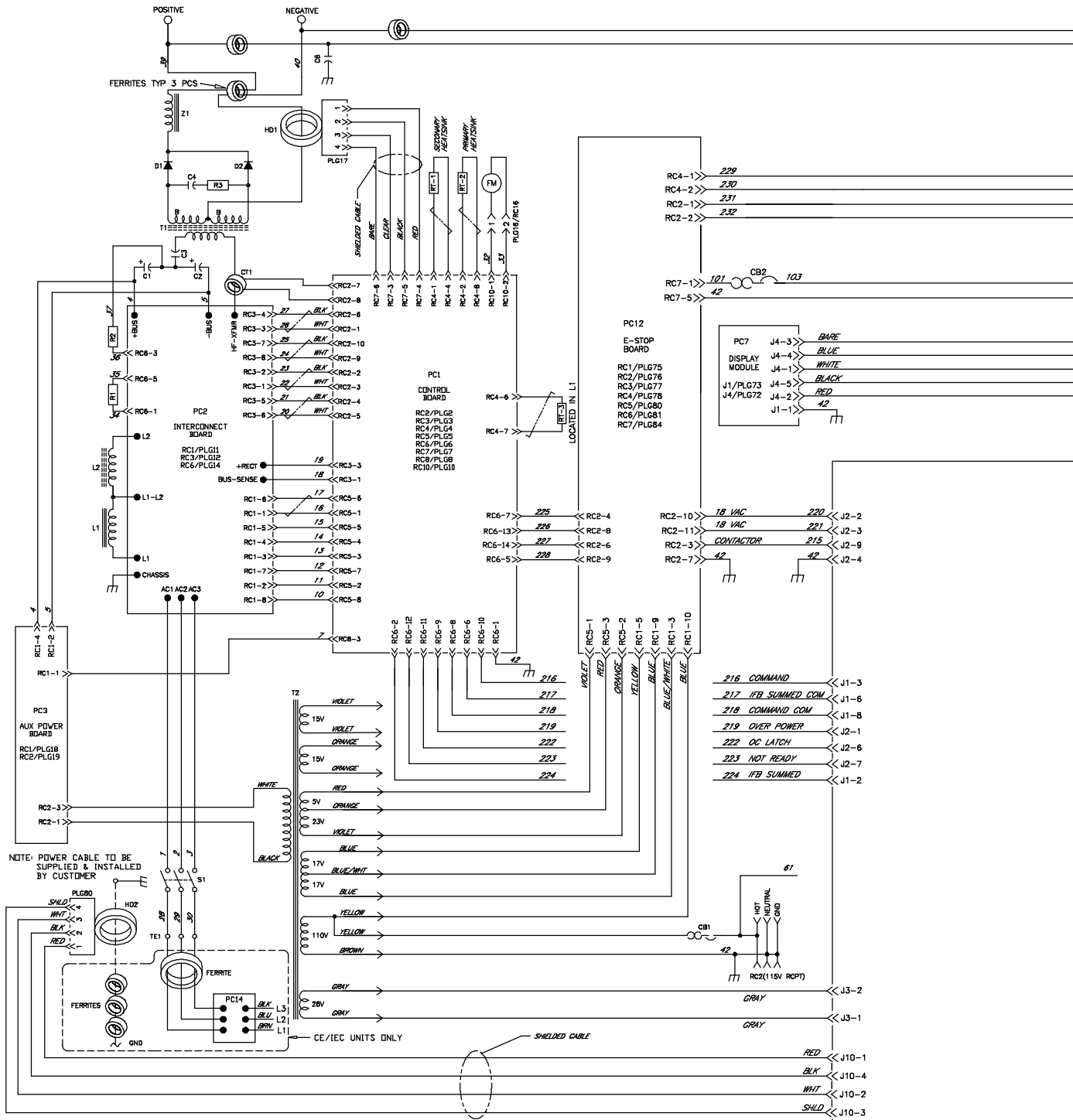

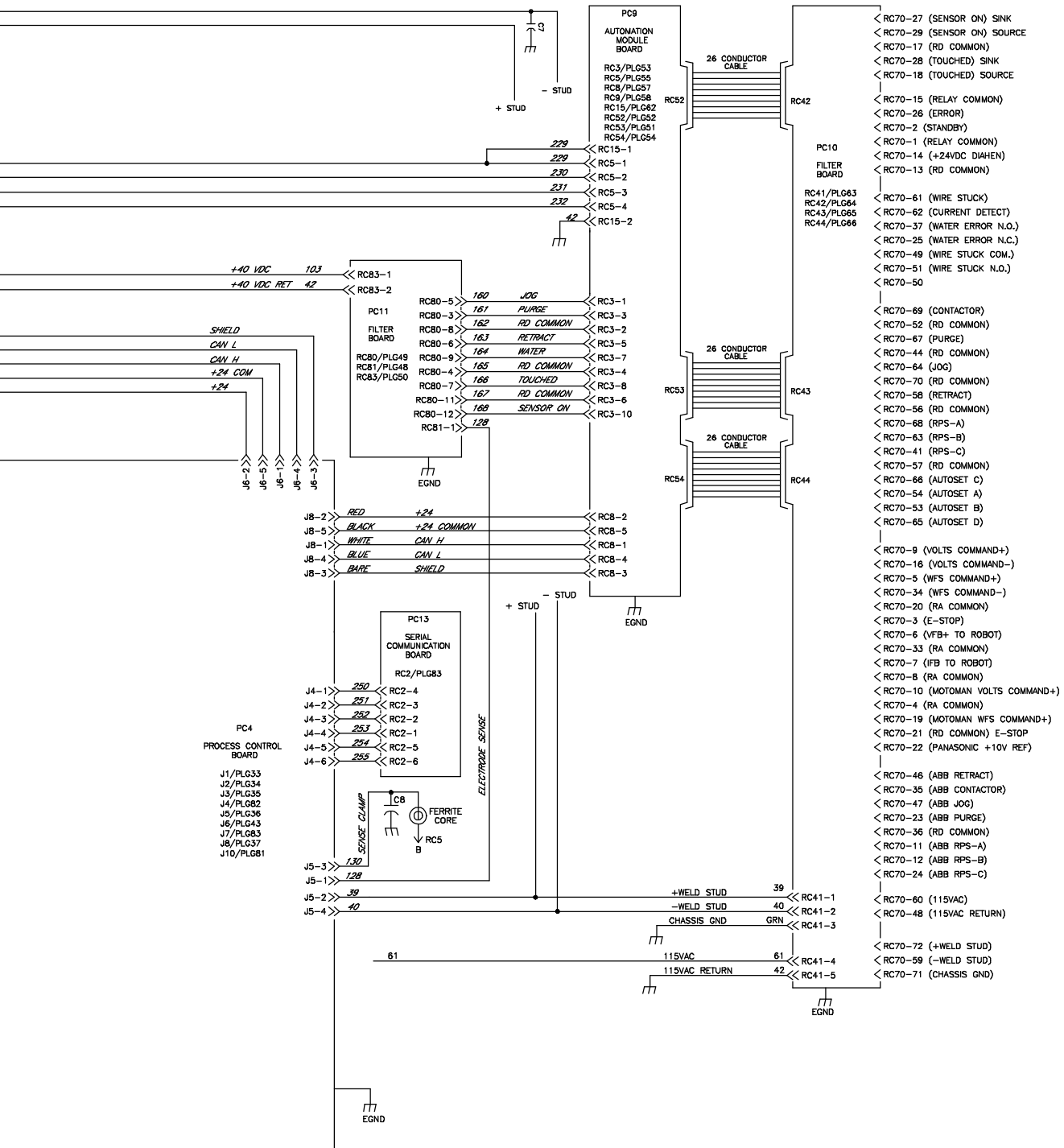



Figure 9-1. Circuit Diagram For Welding Power Source

 ELECTRIC SHOCK HAZARD	WARNING
	<ul style="list-style-type: none"> • Do not touch live electrical parts. • Disconnect input power or stop engine before servicing. • Do not operate with covers removed. • Have only qualified persons install, use, or service this unit.



SECTION 10 – PARTS LIST

 Hardware is common and not available unless listed.

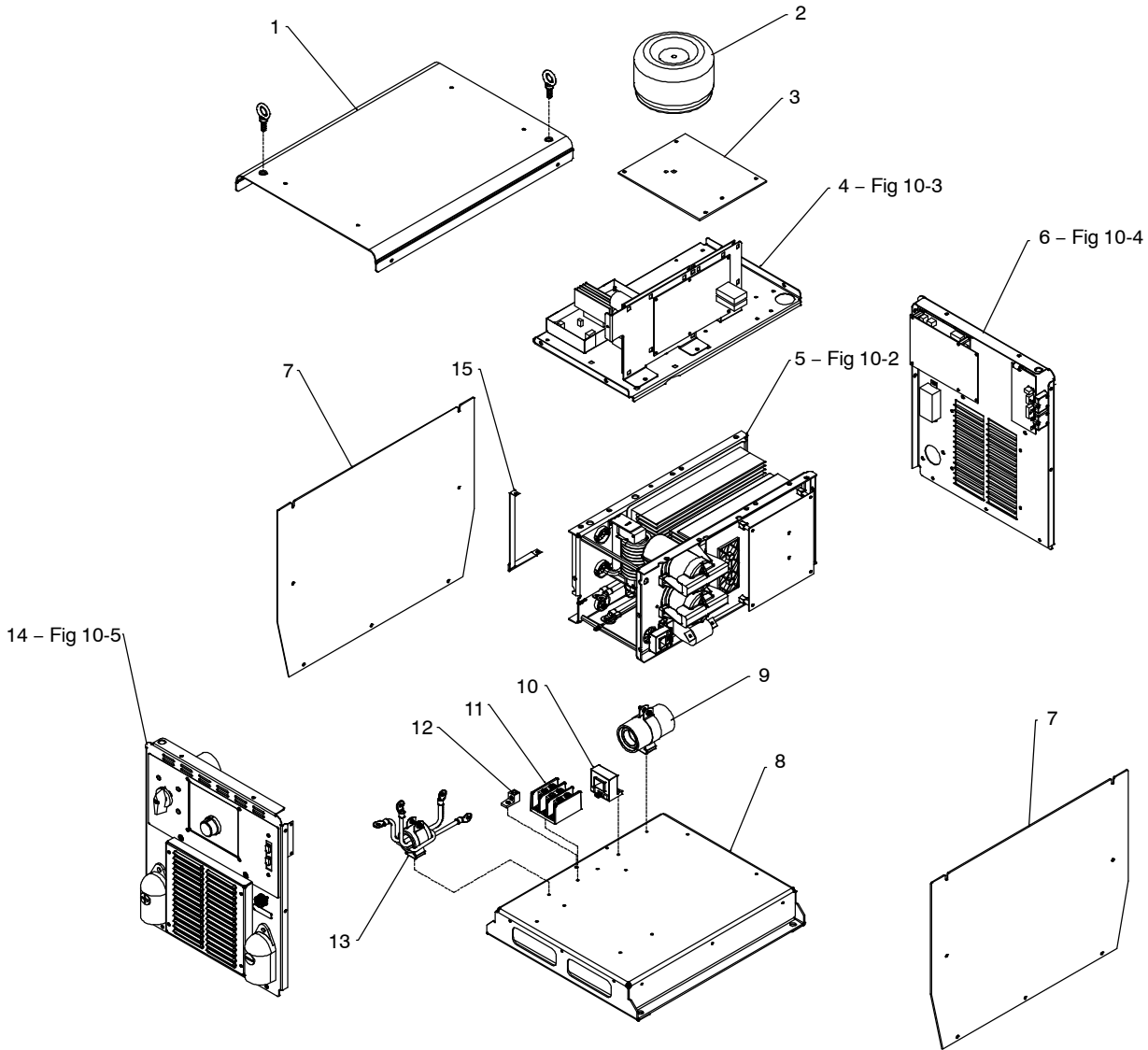

Figure 10-1. Main Assembly

Ref. 249 011-B

Item No.	Dia. Mkgs.	Part No.	Description	Quantity
----------	------------	----------	-------------	----------

Figure 10-1. Main Assembly

...	1	210492	Cover, Top	1
...	2	T2	212543 Xfmr, Control Toroidal 665 VAC Pri 1900 VA 60 Hz	1
...	3	210481	Plate, Mtg Toroid Xfmr	1
...	4	Fig 10-3	Top Tray Assembly	1
...	5	IM1	214597 Windtunnel, LH w/Components (Fig 10-2)	1
...		IM2	222958 Windtunnel, RH w/Components (Fig 10-2)	1
...	6	Fig 10-4	Rear Panel Assembly	1
...	7	230260	Panel, Side W/Insulator	2
...	8	210482	Base	1
...	9	213386	Assembly, Filter (Primary)	1
...	10	HD2	182918 Transducer, Current 400A Module Supply V +/- 15V	1
...			250782 LEM Cable	1
...	11	198951	Terminal Block	1
...	12	148025	Lug, Univ W/SCR 600V 2/0-6 Wire .266 Stud	1
...	13	226550	Filter Assy, Secondary	1
...	14	Fig 10-5	Front Panel Assembly	1
...	15	228897	Strap, Grounding 26.75 in	1

+When ordering a component originally displaying a precautionary label, the label should also be ordered.

To maintain the factory original performance of your equipment, use only Manufacturer's Suggested Replacement Parts. Model and serial number required when ordering parts from your local distributor.

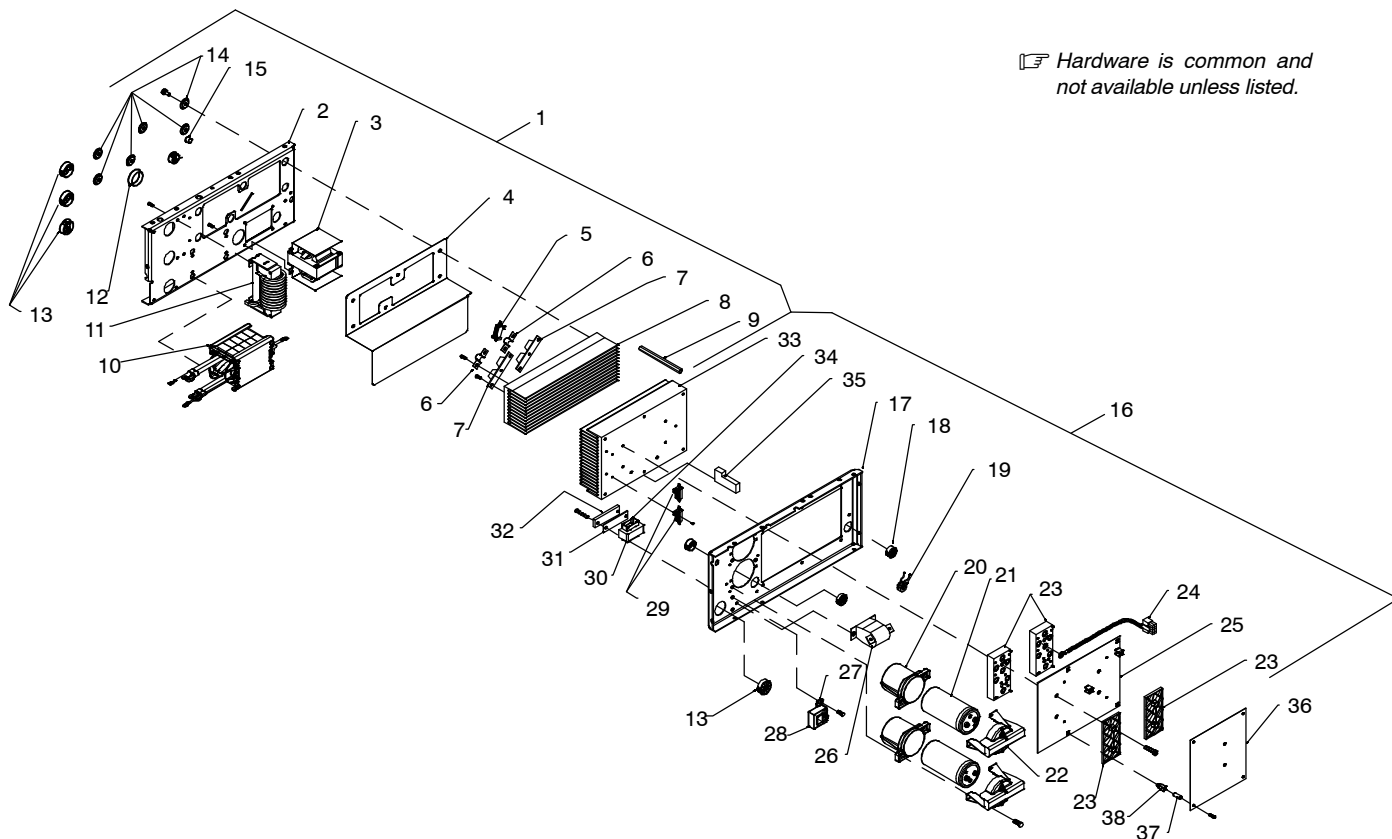

☞ Hardware is common and not available unless listed.

Figure 10-2. Windtunnel Assembly LH And RH

802 955-A

Item No.	Dia. Mkgs.	Part No.	Description	Quantity
----------	------------	----------	-------------	----------

Figure 10-2. Windtunnel Assembly LH And RH (Fig 10-1 Item 6)

...	1	214597	...	Windtunnel, LH w/Components (including).	1
...	2	196351	...	Windtunnel, LH	1
...	3	L1	213940	Inductor, Input	1
...	4	214519	...	Insulator, Heat Sink Rectifier	1
...	5	R3, C4	233052	Resistor/Capacitor	1
...	6	199840	...	Bus Bar, Diode	2
...	7	D1, D2	201531	Kit, Diode Power Module	2
...	8	196347	...	Heat Sink, Rectifier	1
...	9	196349	...	Spacer, Windtunnel	3
...	10	T1	203408	Xfmr, HF Litz/Litz	1
...	11	Z1	220496	Output Inductor Assy	1
...	12	170647	...	Bushing, Snap-in Nyl 1.312 Id X 1.500 Mtg Hole	2
...	13	179276	...	Bushing, Snap-in Nyl 1.000 Id X 1.375 Mtg Hole Cent	4
...	14	196355	...	Insulator, Screw	6
...	15	010546	...	Bushing, Snap-in Nyl .375 Id X .500 Mtg Hole	1
...	16	222958	...	Windtunnel, RH w/Components (including)	1
...	17	196332	...	Windtunnel, RH	1
...	18	030170	...	Bushing, Snap-in Nyl .750 Id X 1.000 Mtg Hole Cent	2
...	19	196259	...	Plugs, w/Leads & Current Xfmr (including)	1
...		115092	...	Housing, Plug & Skts	1
...		115091	...	Housing, Plug & Skts	1
...	CT1	196231	...	Xfmr, Current Sensing 200/1	1

*Recommended Spare Parts.

+When ordering a component originally displaying a precautionary label, the label should also be ordered.

To maintain the factory original performance of your equipment, use only Manufacturer's Suggested Replacement Parts. Model and serial number required when ordering parts from your local distributor.

Item No.	Dia. Mkgs.	Part No.	Description	Quantity
----------	------------	----------	-------------	----------

Figure 10-2. Windtunnel Assembly LH And RH (Fig 10-1 Item 6)

... 20		201695	Clamp, Capacitor (Bottom)	2
... 21	C1, C2	203912	Capacitor, Elctlt 2400 Uf 500 VDC Can 2.5 Dia	2
... 22		210507	Clamp, Capacitor (Top) Machined	2
... 23		**217625	Kit, Input/Pre-regulator And Inverter Module	1
... 24	RT1,RT2,RT3	214015	Thermistor, NTC 30K Ohm @ 25 Deg C 7&18in Lead	3
... 25	PC2	222661	Circuit Card Assy, Power Interconnect	1
		199107	Clip,Wire Std .20-.30 Bndf .156hole .031-.078thk	1
		199108	Clip,Wire Std .30-.40 Bndf .156hole .031-.078thk	1
... 26	C3	196143	Capacitor, Polyp Met Film 16. Uf 400 VAC 10%	1
... 27		196378	Bracket, Mtg Current Xfmr	1
... 28	HD1	182918	Transducer, Current 400A Module Supply V +/- 15v	1
		196384	Cable, Transducer 20in	1
... 29	R1, R2	196343	Resistors, W/Leads & Plug	1
		196840	Insulator, Resistors/Interface Board	1
... 30		109056	Core, Ferrite E 2.164 Lg X 1.094 High X .826 Wide	1
... 31		196514	Gasket, Inductor Mounting	2
... 32		196512	Bracket, Inductor Mounting	2
... 33		196330	Heat Sink, Power Module	1
... 34	L2	196345	Coil, Inductor (Pre-regulator)	1
... 35		196588	Baffle, Foam Rubber (Lower)	1
		196365	Plugs, w/Leads (Fan)	1
		199136	Plugs, w/Leads (PC2 To PC1)	1
... 36	PC1	235303	Circuit Card Assy, Control (Inverter 300A)	1
... 37		204846	Insulator, Screw	4
... 38		083147	Grommet, Scr No 8/10 Panel Hole .312 Sq .500 High	4

+When ordering a component originally displaying a precautionary label, the label should also be ordered.

**This kit contains two modules and instructions. Be sure to follow the field kit instructions when performing the installation.

To maintain the factory original performance of your equipment, use only Manufacturer's Suggested Replacement Parts. Model and serial number required when ordering parts from your local distributor.

☞ Hardware is common and not available unless listed.

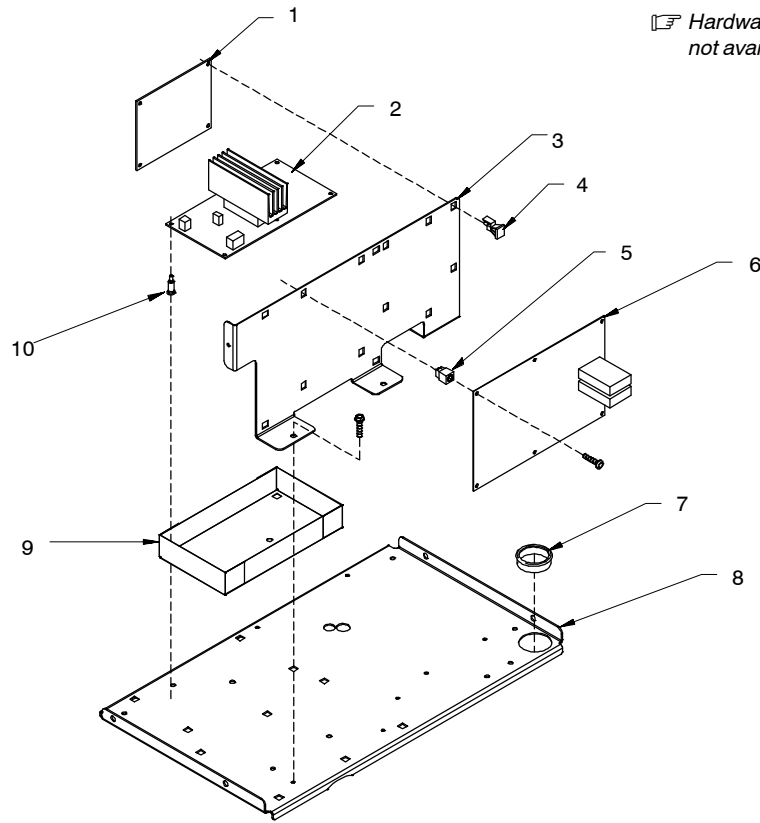

Ref. 802 916-B

Figure 10-3. Top Tray Assembly

Item No.	Dia. Mkgs.	Part No.	Description	Quantity
----------	------------	----------	-------------	----------

Figure 10-3. Top Tray Assembly (Fig 10-1 Item 4)

...	1	PC12	209676	Circuit Card Assy, E-stop	1
...	2	PC3	231928	Circuit Card Assy, Aux Power	1
...	3		210490	Bracket, Mtg PC Card	1
...	4		134201	Stand-Off, PC Card .312/.375/Post&Lock .43	4
...	5		083147	Grommet, SCR No 8/10 Panel Hole .312 Sq .500 High	4
...	6	PC4		Process Control Module (PCM) (see Table 9-1)	1
...	7		170647	Bushing, Snap-in Nyl 1.312 Id X 1.500 Mtg Hole	1
...	8		210491	Tray, Mtg PC Card	1
...	9		223439	Insulator, Circuit Card (Aux Power)	1
...	10		198122	Stand-Off Support, PC Card .250 w/Post&Lock .500	1

+When ordering a component originally displaying a precautionary label, the label should also be ordered.

To maintain the factory original performance of your equipment, use only Manufacturer's Suggested Replacement Parts. Model and serial number required when ordering parts from your local distributor.

☞ Hardware is common and not available unless listed.

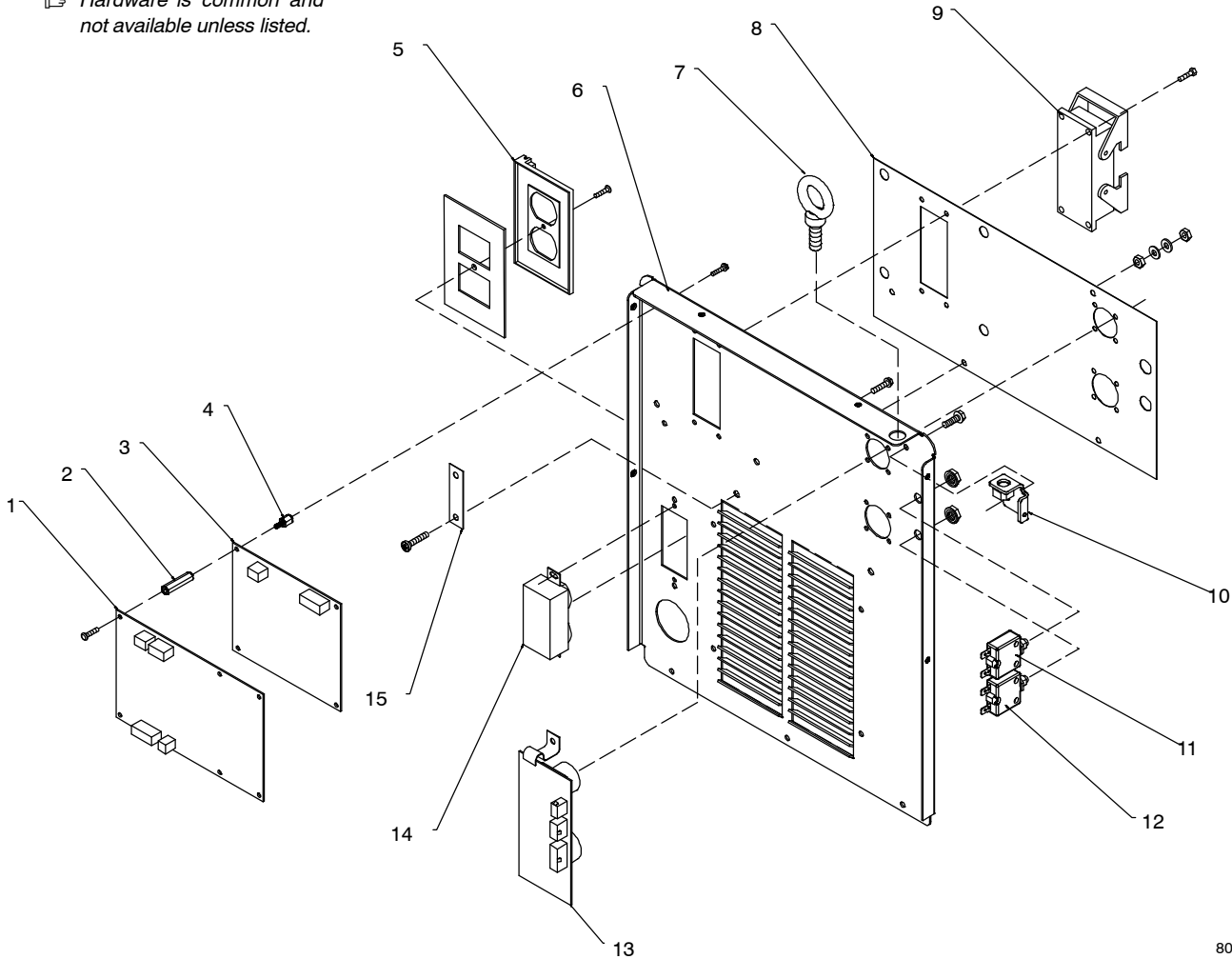

803 681-B

Figure 10-4. Rear Panel Assembly

Item No.	Dia. Mkgs.	Part No.	Description	Quantity
----------	------------	----------	-------------	----------

Figure 10-4. Rear Panel Assembly (Fig 10-1 Item 8)

...	1	PC9	221279	Automation Interface Module	1
...	2		212628	Stand-off, no 6-32 x 1.000 lg .250 hex nyl fem	4
...	3	PC10	214855	Circuit Card Assy, Robot Interface Filter HF	1
...	4		207676	Stand-off, no 6-32 x .250 lg .250 hex	4
...	5		217297	Cover, Receptacle Weatherproof Duplex Rcpt	1
...	6		210479	Panel, Rear	1
...	7		210358	Bolt, eye shld thd stem .500-13 X 1.500	1
...	8		210505	Nameplate, Rear	1
...	9		201058	Connector, Rect 72 Pin Assy	1
...	10		210483	Bracket, lift eye	1
...	11	CB1	083432	Supplementary Protector, Man Reset 1P 10A 250VAC Frict	1
...	12	CB2	093995	Supplementary Protector, Man Reset 1P 15A 250VAC Frict	1
...	13	PC11	216213	Circuit Card Assy, Motor Filter HF	1
...	14	RC2	604176	Receptacle, w/Leads (115V Duplex)	1
...	15		216596	Strap, Grounding 4.50 in long	1

*Recommended Spare Parts.

+When ordering a component originally displaying a precautionary label, the label should also be ordered.

To maintain the factory original performance of your equipment, use only Manufacturer's Suggested Replacement Parts. Model and serial number required when ordering parts from your local distributor.

☞ Hardware is common and not available unless listed.

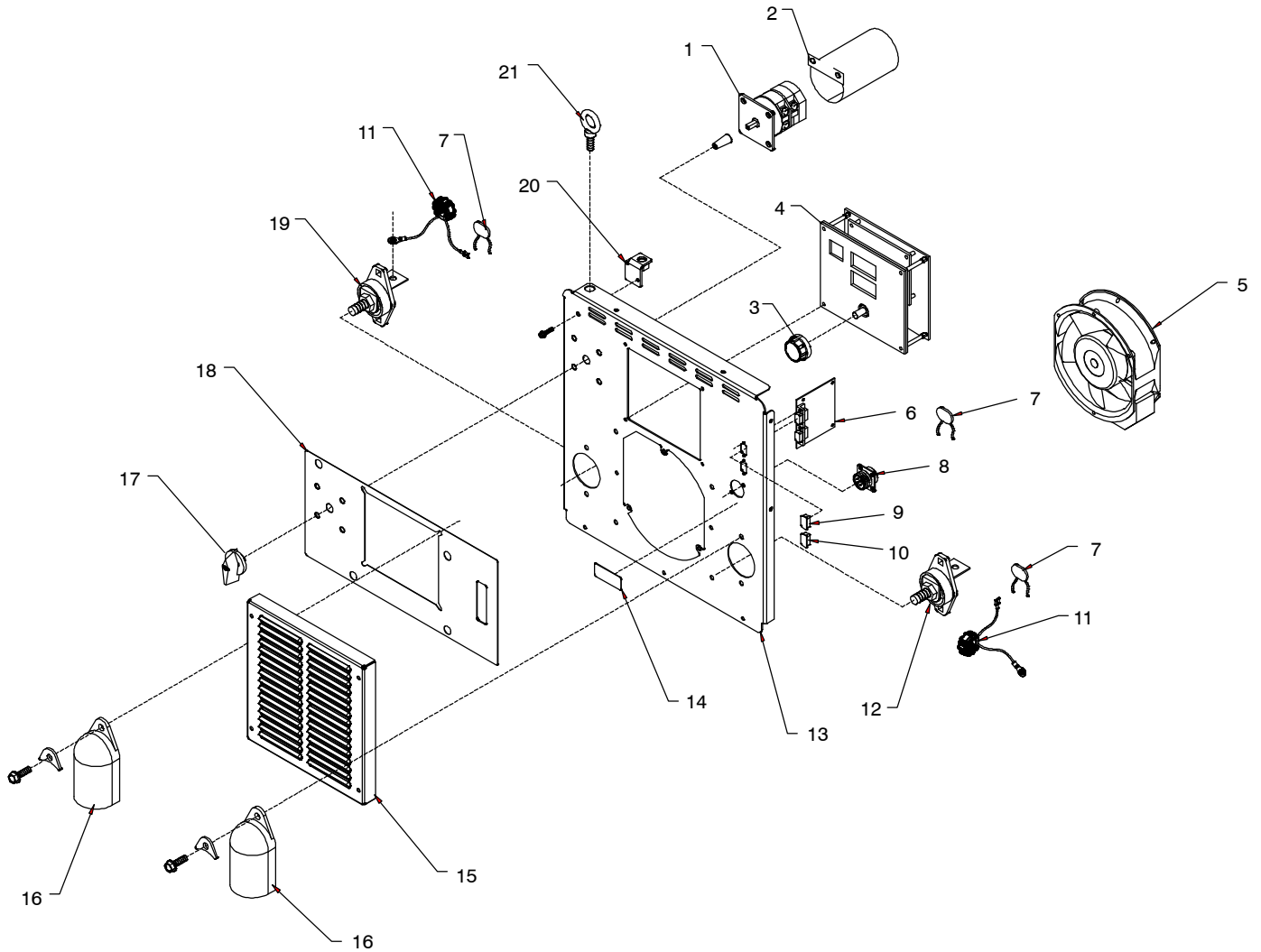

Ref. 803 682-B

Figure 10-5. Front Panel Assembly

Item No.	Dia. Mkgs.	Part No.	Description	Quantity
----------	------------	----------	-------------	----------

Figure 10-5. Front Panel Assembly (Fig 10-1 Item 14)

...	1	S1	207456	Switch Assy, Rotary 2 Posn 1P 40A 600VAC PNLMTG 90Deg	1
...	2		207895	Insulator,Switch Power	1
...	3		179851	Knob, Pointer 1.670 Dia X .250 Id Push On W/Spring	1
...	4			User Interface Module (UIM) (see Table 9-1)	1
...	5	FM	196313	Fan, Muffin 115V 50/60 Hz 3000 Rpm 6.378 Mtg Holes	2
...	6	PC13	208071	Circuit Card Assy,ISO/COMM	1
...	7	C6, C7, C8	222488	Capacitor Assy	3
...	8	RC5	214664	Receptacle, Common Mode Choke	1
...	9		216965	Cover, Connector D-sub 9 skt Female w/Chain	1

*Recommended Spare Parts.

+When ordering a component originally displaying a precautionary label, the label should also be ordered.

To maintain the factory original performance of your equipment, use only Manufacturer's Suggested Replacement Parts. Model and serial number required when ordering parts from your local distributor.

Item No.	Dia. Mkgs.	Part No.	Description	Quantity
----------	------------	----------	-------------	----------

Figure 10-5. Front Panel Assembly (Fig 10-1 Item 14) (Continued)

... 10	...	216966	... Cover, Connector D-sub 9 pin Male w/Chain	1
... 11	...	213102	... Choke, Common Mode w/Leads	2
... 12	...	210866	... Terminal, pwr output black	1
... 13	...	210476	... Panel, Front	1
... 14	...	219843	... Label, Volt Sense	1
... 15	...	207979	... Box, Louver	1
... 16	...	186621	... Boot, Generic	2
... 17	...	231056	... Knob,Black Electros witch	1
... 18	...	212779	... Nameplate, Front	1
... 19	...	210865	... Terminal, pwr output red	1
... 20	...	210483	... Bracket, lift eye	1
... 21	...	210358	... Bolt, eye shld thd stem .500-13 X 1.500	1

*Recommended Spare Parts.

+When ordering a component originally displaying a precautionary label, the label should also be ordered.

To maintain the factory original performance of your equipment, use only Manufacturer's Suggested Replacement Parts. Model and serial number required when ordering parts from your local distributor.

Ordering Information For PCM, AIM And UIM Circuit Boards

The UIM, AIM and PCM boards must have compatible programs in order to communicate together and provide proper system performance. If the program has been updated since the system was received, the original program revision may not match the serial number of the PipePro 300 shown in Table 9-1. In order to provide the correct replacement board, it is necessary to know the program revision for each of the boards in the PipePro 300.

Follow the procedure to Check Program Revision for each board according to Section 5-15.

The last three numbers of the program and the program revision letter appear on the display. All three boards will match one of the rows horizontally in Table 9-1. The WFCM board will appear on the display for earlier versions of program. This board is not used in the PipePro 300 so it can be ignored in this case. Once the board program revisions are identified, use Table 9-1 to select the proper replacement board part number(s).

If the program revision cannot be found due to board failure, the serial number and/or knowledge of a prior update must be used to determine the correct board number. Another welding power source at the same location may be used to determine the program revision to remain consistent.

Table 9-1. Program Revisions For Circuit Boards

UIM			AIM		PCM		Original Manufacture Starting w/Serial No.
	Stock Number		Software	Board	Software	Board	
	907489	907435					
Software	Board	Board	Software	Board	Software	Board	
226429D	246895	249383	226431B	238019	222230H	246554	LK310043G
226429E	247937	249384	226431B	238019	222230J	247935	MA120110G

TRUE BLUE[®]

WARRANTY

Effective January 1, 2012

(Equipment with a serial number preface of MC or newer)

This limited warranty supersedes all previous Miller warranties and is exclusive with no other guarantees or warranties expressed or implied.

Warranty Questions?

Call
1-800-4-A-MILLER
for your local
Miller distributor.

Your distributor also gives
you ...

Service

You always get the fast,
reliable response you
need. Most replacement
parts can be in your
hands in 24 hours.

Support

Need fast answers to the
tough welding questions?
Contact your distributor.
The expertise of the
distributor and Miller is
there to help you, every
step of the way.

LIMITED WARRANTY – Subject to the terms and conditions below, Miller Electric Mfg. Co., Appleton, Wisconsin, warrants to its original retail purchaser that new Miller equipment sold after the effective date of this limited warranty is free of defects in material and workmanship at the time it is shipped by Miller. THIS WARRANTY IS EXPRESSLY IN LIEU OF ALL OTHER WARRANTIES, EXPRESS OR IMPLIED, INCLUDING THE WARRANTIES OF MERCHANTABILITY AND FITNESS.

Within the warranty periods listed below, Miller will repair or replace any warranted parts or components that fail due to such defects in material or workmanship. Miller must be notified in writing within thirty (30) days of such defect or failure, at which time Miller will provide instructions on the warranty claim procedures to be followed.

Miller shall honor warranty claims on warranted equipment listed below in the event of such a failure within the warranty time periods. All warranty time periods start on the delivery date of the equipment to the original end-user purchaser, and not to exceed one year after the equipment is shipped to a North American distributor or eighteen months after the equipment is shipped to an International distributor.

1. 5 Years Parts — 3 Years Labor
 - * Original Main Power Rectifiers Only to Include SCRs, Diodes, and Discrete Rectifier Modules
2. 3 Years — Parts and Labor
 - * Engine Driven Welding Generators
(NOTE: Engines are Warranted Separately by the Engine Manufacturer.)
 - * Inverter Power Sources (Unless Otherwise Stated)
 - * Plasma Arc Cutting Power Sources
 - * Process Controllers
 - * Semi-Automatic and Automatic Wire Feeders
 - * Smith 30 Series Flowgauge and Flowmeter Regulators (No Labor)
 - * Transformer/Rectifier Power Sources
 - * Water Coolant Systems (Integrated)
3. 2 Years — Parts
 - * Auto-Darkening Helmet Lenses (No Labor)
4. 1 Year — Parts and Labor Unless Specified
 - * Automatic Motion Devices
 - * CoolBelt and CoolBand Blower Unit (No Labor)
 - * External Monitoring Equipment and Sensors
 - * Field Options
(NOTE: Field options are covered for the remaining warranty period of the product they are installed in, or for a minimum of one year — whichever is greater.)
 - * Flowgauge and Flowmeter Regulators (No Labor)
 - * RFCS Foot Controls (Except RFCS-RJ45)
 - * Fume Extractors
 - * HF Units
 - * ICE/XT Plasma Cutting Torches (No Labor)
 - * Induction Heating Power Sources, Coolers
(NOTE: Digital Recorders are Warranted Separately by the Manufacturer.)
 - * Load Banks
 - * Motor Driven Guns (w/exception of Spoolmate Spoolguns)
 - * PAPR Blower Unit (No Labor)
 - * Positioners and Controllers
 - * Racks
 - * Running Gear/Trailers
 - * Spot Welders
 - * Subarc Wire Drive Assemblies
 - * Water Coolant Systems (Non-Integrated)
 - * Weldcraft-Branded TIG Torches (No Labor)
 - * Wireless Remote Foot/Hand Controls and Receivers
 - * Work Stations/Weld Tables (No Labor)
5. 6 Months — Parts
 - * Batteries
 - * Bernard Guns (No Labor)
 - * Tregaskiss Guns (No Labor)

6. 90 Days — Parts
 - * Accessory (Kits)
 - * Canvas Covers
 - * Induction Heating Coils and Blankets, Cables, and Non-Electronic Controls
 - * M-Guns
 - * MIG Guns and Subarc (SAW) Guns
 - * Remote Controls and RFCS-RJ45
 - * Replacement Parts (No labor)
 - * Roughneck Guns
 - * Spoolmate Spoolguns

Miller's True Blue[®] Limited Warranty shall not apply to:

1. **Consumable components; such as contact tips, cutting nozzles, contactors, brushes, relays, work station table tops and welding curtains, or parts that fail due to normal wear. (Exception: brushes and relays are covered on all engine-driven products.)**
2. Items furnished by Miller, but manufactured by others, such as engines or trade accessories. These items are covered by the manufacturer's warranty, if any.
3. Equipment that has been modified by any party other than Miller, or equipment that has been improperly installed, improperly operated or misused based upon industry standards, or equipment which has not had reasonable and necessary maintenance, or equipment which has been used for operation outside of the specifications for the equipment.

MILLER PRODUCTS ARE INTENDED FOR PURCHASE AND USE BY COMMERCIAL/INDUSTRIAL USERS AND PERSONS TRAINED AND EXPERIENCED IN THE USE AND MAINTENANCE OF WELDING EQUIPMENT.

In the event of a warranty claim covered by this warranty, the exclusive remedies shall be, at Miller's option: (1) repair; or (2) replacement; or, where authorized in writing by Miller in appropriate cases, (3) the reasonable cost of repair or replacement at an authorized Miller service station; or (4) payment of or credit for the purchase price (less reasonable depreciation based upon actual use) upon return of the goods at customer's risk and expense. Miller's option of repair or replacement will be F.O.B., Factory at Appleton, Wisconsin, or F.O.B. at a Miller authorized service facility as determined by Miller. Therefore no compensation or reimbursement for transportation costs of any kind will be allowed.

TO THE EXTENT PERMITTED BY LAW, THE REMEDIES PROVIDED HEREIN ARE THE SOLE AND EXCLUSIVE REMEDIES. IN NO EVENT SHALL MILLER BE LIABLE FOR DIRECT, INDIRECT, SPECIAL, INCIDENTAL OR CONSEQUENTIAL DAMAGES (INCLUDING LOSS OF PROFIT), WHETHER BASED ON CONTRACT, TORT OR ANY OTHER LEGAL THEORY.

ANY EXPRESS WARRANTY NOT PROVIDED HEREIN AND ANY IMPLIED WARRANTY, GUARANTY OR REPRESENTATION AS TO PERFORMANCE, AND ANY REMEDY FOR BREACH OF CONTRACT TORT OR ANY OTHER LEGAL THEORY WHICH, BUT FOR THIS PROVISION, MIGHT ARISE BY IMPLICATION, OPERATION OF LAW, CUSTOM OF TRADE OR COURSE OF DEALING, INCLUDING ANY IMPLIED WARRANTY OF MERCHANTABILITY OR FITNESS FOR PARTICULAR PURPOSE, WITH RESPECT TO ANY AND ALL EQUIPMENT FURNISHED BY MILLER IS EXCLUDED AND DISCLAIMED BY MILLER.

Some states in the U.S.A. do not allow limitations of how long an implied warranty lasts, or the exclusion of incidental, indirect, special or consequential damages, so the above limitation or exclusion may not apply to you. This warranty provides specific legal rights, and other rights may be available, but may vary from state to state.

In Canada, legislation in some provinces provides for certain additional warranties or remedies other than as stated herein, and to the extent that they may not be waived, the limitations and exclusions set out above may not apply. This Limited Warranty provides specific legal rights, and other rights may be available, but may vary from province to province.





Owner's Record

Please complete and retain with your personal records.

Model Name

Serial/Style Number

Purchase Date

(Date which equipment was delivered to original customer.)

Distributor

Address

City

State

Zip



For Service

Contact a DISTRIBUTOR or SERVICE AGENCY near you.

Always provide Model Name and Serial/Style Number.

Contact your Distributor for:

Welding Supplies and Consumables

Options and Accessories

Personal Safety Equipment

Service and Repair

Replacement Parts

Training (Schools, Videos, Books)

Technical Manuals (Servicing Information and Parts)

Circuit Diagrams

Welding Process Handbooks

To locate a Distributor or Service Agency visit www.millerwelds.com or call 1-800-4-A-Miller

Contact the Delivering Carrier to:

File a claim for loss or damage during shipment.

For assistance in filing or settling claims, contact your distributor and/or equipment manufacturer's Transportation Department.

Miller Electric Mfg. Co.

An Illinois Tool Works Company
1635 West Spencer Street
Appleton, WI 54914 USA

International Headquarters—USA

USA Phone: 920-735-4505 Auto-Attended
USA & Canada FAX: 920-735-4134
International FAX: 920-735-4125

For International Locations Visit
www.MillerWelds.com

